

**INTRODUCTION AND
PIPING PRACTICES**

**PRODUCT/
PROCESS**

**DUAL
LIQUID**

**QUENCH/
LEAK DETECTION**

**DUAL GAS/
CONTAINMENT**



PPC

Mechanical Seal Piping Plans

4th Edition



Importance of Piping Plans

The key to maximizing mechanical seal reliability and minimizing total cost of ownership is in controlling the environment in and around the seal. The standards put forth by API Standard 682 are meant to give you the tools to optimize product temperatures, maximize face lubrication, minimize leakage and reduce emissions.

In most cases, it is not possible to install and utilize every plan that seems applicable. In theory, to maximize seal life you would install the optimum solutions. In reality, you have to consider budget constraints, old equipment, equipment restrictions, lack of familiarity, and conflicting solutions/process compatibility.

This booklet is a tool to help you find the optimum solution for your application. The illustrations are intended to be simple and informative, utilizing straightforward and generic language. We recommend consulting with your PPC Representative to assist you in maximizing the performance of your mechanical seals at the lowest cost of ownership.

Piping and Instrumentation Key



	VALVE, NORMALLY CLOSED		HEAT EXCHANGER		TEMPERATURE INDICATOR		TEMPERATURE TRANSMITTER, LOCAL INDICATOR
	VALVE, NORMALLY OPEN		CYCLONE SEPARATOR		FLOW INDICATOR		FLOW TRANSMITTER, LOCAL INDICATOR
	NEEDLE VALVE		PRESSURE RELIEF VALVE		PRESSURE INDICATOR		PRESSURE TRANSMITTER, LOCAL INDICATOR
	CHECK VALVE		PRESSURE CONTROL VALVE		LEVEL INDICATOR		DIFFERENTIAL PRESSURE TRANSMITTER, LOCAL INDICATOR
	ORIFICE		BLADDER ACCUMULATOR		LEVEL TRANSMITTER		LEVEL TRANSMITTER, LOCAL INDICATOR
	Y-STRAINER		PISTON ACCUMULATOR		STEAM TRAP		
	FILTER		RESERVOIR				



Seal Terminology

API Standard 682 Seal Arrangements

- **Arrangement 1:** One seal per cartridge assembly. Also referred to as a “single” seal.
- **Arrangement 2:** Two seals per cartridge assembly with a chamber between the two seals at a LOWER pressure than the pump seal chamber. May use a liquid buffer, gas buffer, or no buffer fluid. Has also been referred to as a “tandem” seal.
- **Arrangement 3:** Two seals per cartridge assembly with a chamber between the two seals at a GREATER pressure than the pump seal chamber. May use a liquid barrier or gas barrier fluid. Has also been referred to as a “double” seal.

Note: Both Arrangements 2 and 3 are also referred to as “dual” seals.



Seal Terminology

Flush: Fluid provided on the process side of a seal to cool, lubricate, or clean the seal faces. Mixes with process.

Buffer Fluid: Fluid provided by an external source at a pressure LOWER than the pump seal chamber. Used in Arrangement 2 seals to dilute process leakage and/or lubricate seal faces.

Barrier Fluid: Fluid provided by an external source at a pressure GREATER than the pump seal chamber. Used in Arrangement 3 seals to completely isolate the process from the environment.

Quench: Fluid provided on the atmosphere side of a seal to remove or slow down solid formations. Commonly used to prevent coking, crystallization or icing. Typical fluids are water, steam and nitrogen. Does not mix with process.

Process Seal: Seal in contact with the product or process in an Arrangement 1, 2 or 3. May also be referred to as the inner seal in Arrangements 2 and 3.

Containment Seal: Special version of outer seal in an Arrangement 2. Normally in contact with gas buffer or no buffer but will temporarily seal process fluid in case of inner seal failure.



Typical Arrangement- Plan 23

- Minimize piping line losses
- Use large radius bends
- Minimize 90° elbows
- Recommended ¾" tubing for connecting lines
- Minimum ½" per 1' slope upwards on all lines from seal gland to cooler

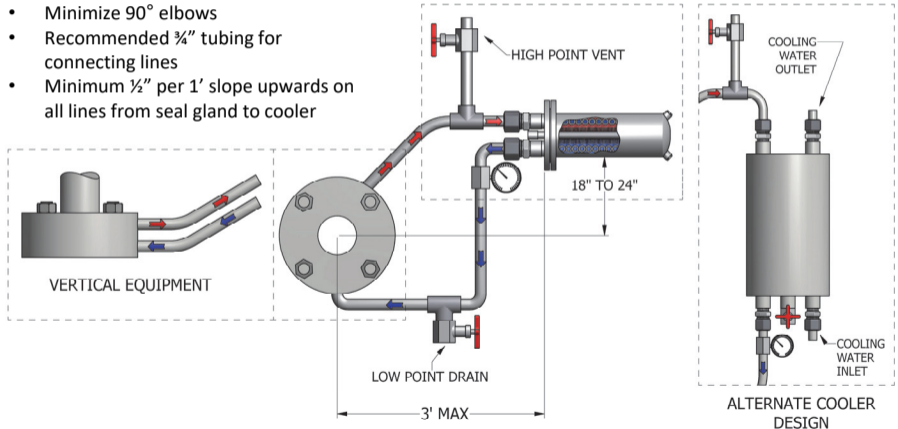

Typical Arrangement- Plan 52 or Plan 53A



- Minimize piping line losses
- Use large radius bends
- Minimize 90° elbows
- Recommended ¾" tubing for connecting lines
- Minimum ½" per 1' slope upwards on all lines from seal gland to reservoir
- Contact PPC Engineering for buffer/barrier fluid recommendations
- Check for correct pressure and level alarm set points

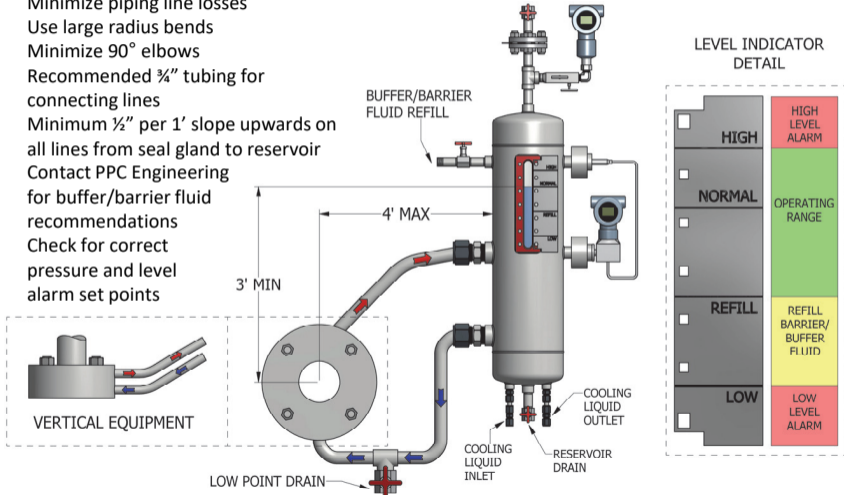



Single/Dual Seals

PLAN 01

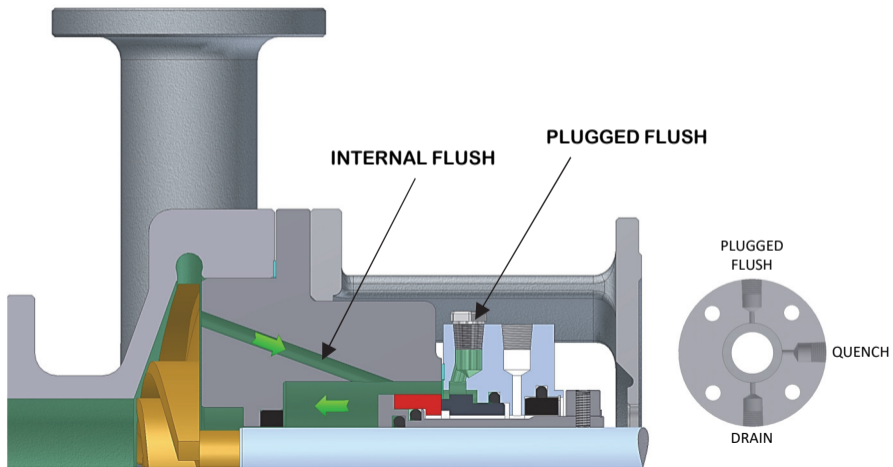

Internal Flush

Description: Plan 01 is an integral recirculation from the pump discharge to the seal chamber. This is an internal version of Plan 11. Recommended for clean process only.

Objective: Dissipate seal generated heat and vent the seal chamber at start-up.

Advantages: No exposed plumbing around pump. Reduces risk of freezing or polymerization of process. Not recommended for vertical pumps.

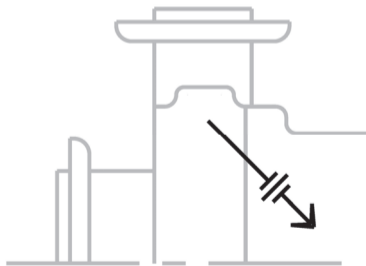



Single/Dual Seals

PLAN 02

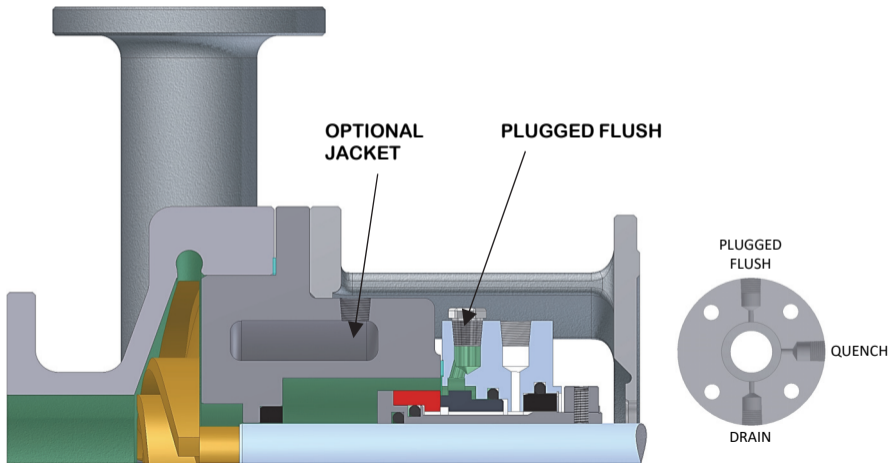



Dead-Ended Seal Chamber

Description: Plan 02 is a dead-ended seal chamber with no recirculation of flush fluid.

Objective: Often used with a jacketed seal chamber to control temperature in high temperature processes. Use only when adequate vapor margin is present in the seal chamber.

Advantages: Little to no maintenance. Process solids are not continuously introduced into seal chamber. Plan 62 with steam can provide additional heating or cooling and minimize coking on hot processes.





Single/Dual Seals

PLAN 03

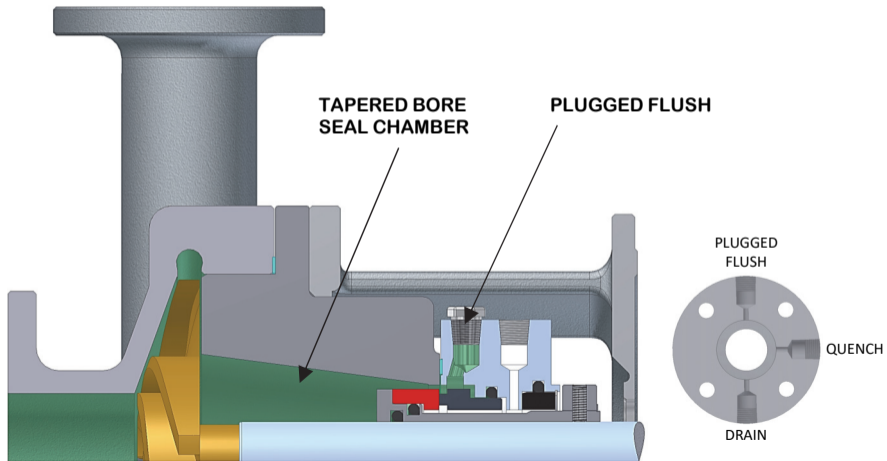



Tapered Seal Chamber

Description: Plan 03 is a dead-ended seal chamber with an open throat, tapered seal chamber and flow modifiers to generate product circulation.

Objective: Dissipate seal generated heat, vent and drain the seal chamber, and aid in the removal of solids.

Advantages: Little to no maintenance. Process solids will not collect as they do in a traditional seal chamber. Use only when adequate vapor margin is present in the seal chamber. Plan 62 with steam can provide additional heating or cooling and minimize coking on hot processes.





Single/Dual Seals

PLAN 11

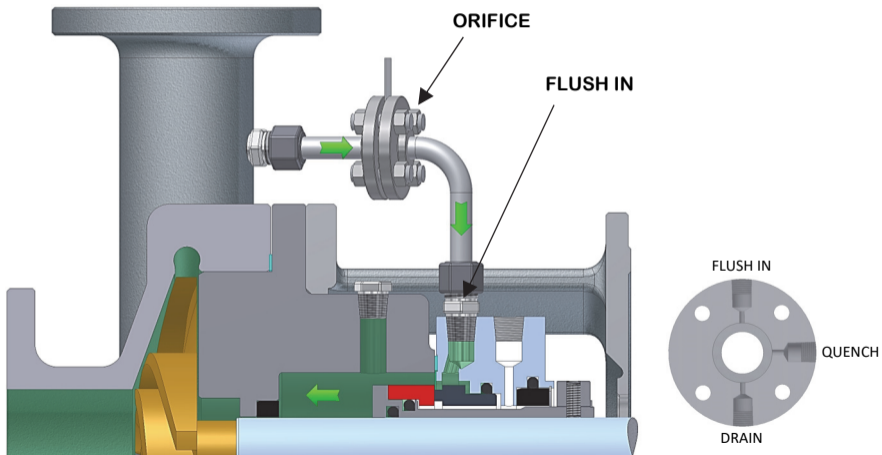



Discharge Flush

Description: Plan 11 is recirculation from pump discharge through an 1/8" minimum flow control orifice (when necessary), to the seal and back into the process through the pump seal chamber.

Objective: Dissipate seal generated heat, vent the seal chamber at start-up and increase the vapor margin in the seal chamber.

Advantages: When used with a close-clearance throat bushing, will raise the pressure in the seal chamber to maintain the process in the liquid state when cooling is not practical. Best for a clean, non-polymerizing process.

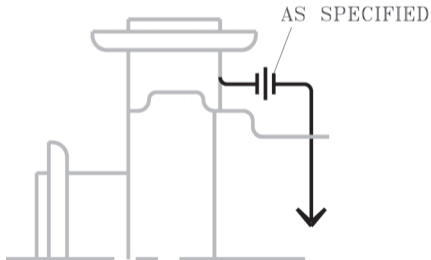



Single/Dual Seals

PLAN 13

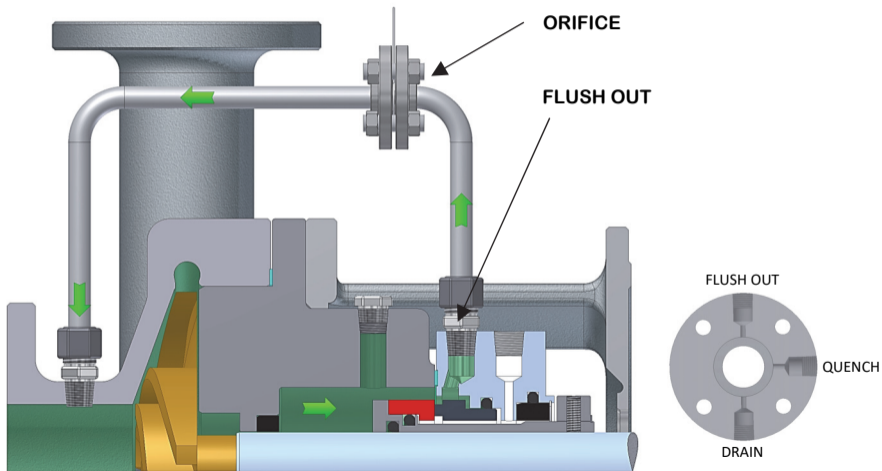



Return to Suction Flush

Description: Plan 13 is recirculation from the seal chamber or gland through an $1/8''$ minimum flow control orifice (when necessary), back to the pump suction. Standard flush plan for vertical pumps.

Objective: Remove seal generated heat and vent vertical pumps.

Advantages: Used in applications where the seal chamber pressure is greater than suction pressure. Can reduce the seal chamber pressure when used along with a close-clearance throat bushing.

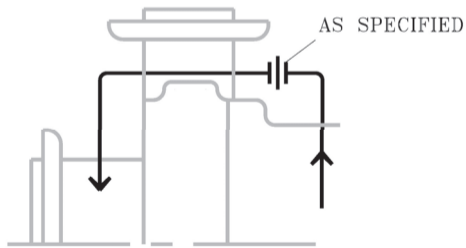



Single/Dual Seals

PLAN 14

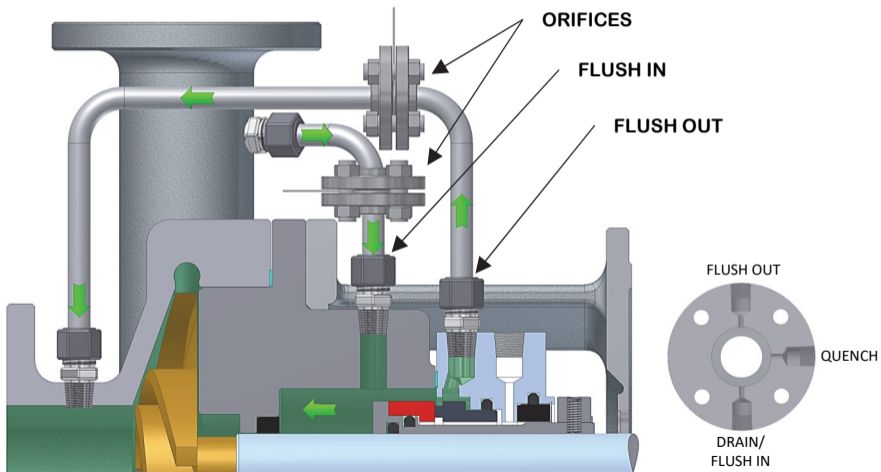



Discharge-Return to Suction Flush

Description: Plan 14 is recirculation from pump discharge through a properly sized flow control orifice (when necessary), to the seal chamber and from the seal chamber through a properly sized flow control orifice (when necessary), to the pump suction. (A combination of Plan 11 and Plan 13)

Objective: Remove seal generated heat and vent vertical pumps while providing adequate seal chamber pressure for process vapor margin and sufficient fluid flow for cooling.

Advantages: Provides pressure and recirculation inside the seal chamber to avoid vaporizing liquids when used along with a close-clearance throat bushing and properly sized orifice.

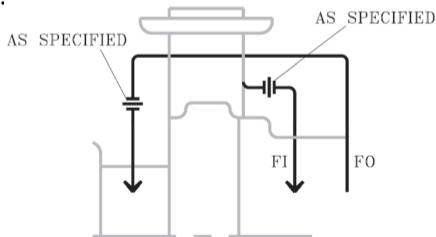



Single/Dual Seals

PLAN 21

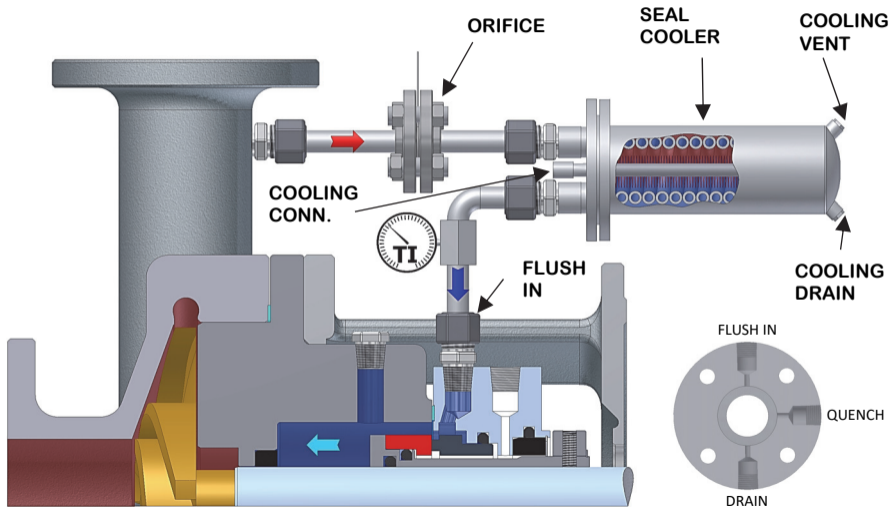



Discharge Through Flush Cooler

Description: Plan 21 is recirculation from pump discharge through an 1/8" minimum flow control orifice (when necessary), and seal flush cooler, then into the seal chamber.

Objective: Cool the process in the seal chamber, improving lubricity and increasing the vapor margin. Reduce coking.

Advantages: Provides cooling through a seal flush cooler. When used with a close-clearance throat bushing, it can raise the pressure in the seal chamber. Recommended over Plan 23 when used in viscous applications that may clog seal flush cooler.

Note: Plan 23 is the preferred plan due to high heat loads put on the seal flush cooler when using Plan 21.

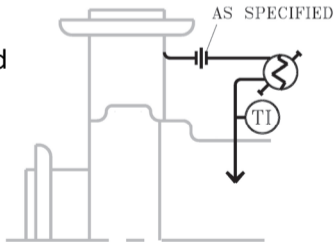



Single/Dual Seals

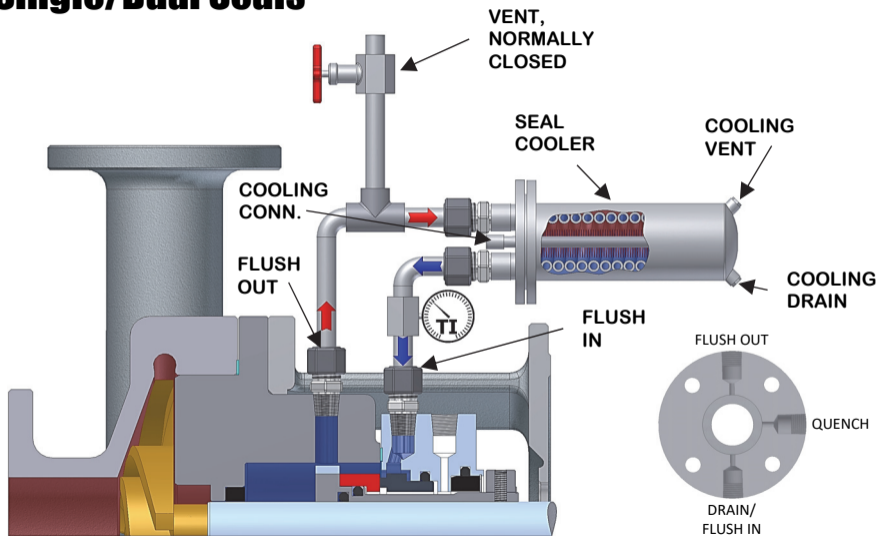



Recirculation Through Flush Cooler

Description: Plan 23 is recirculation of process fluid from the seal chamber, through a seal flush cooler, back into the seal chamber utilizing a pumping ring.

Objective: Cool process, improving lubricity and increasing the vapor margin in the seal chamber. Reduce coking.

Advantages: Has greater cooling efficiency than Plan 21 because it continuously recirculates the seal chamber fluid through the seal flush cooler. It decreases cooler duty, reduces cooler fouling and increases cooler life.

Recommendation: Vent tubing before pump start-up and use close-clearance throat bushing in seal chamber.

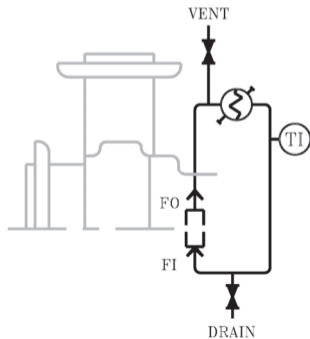



Single/Dual Seals

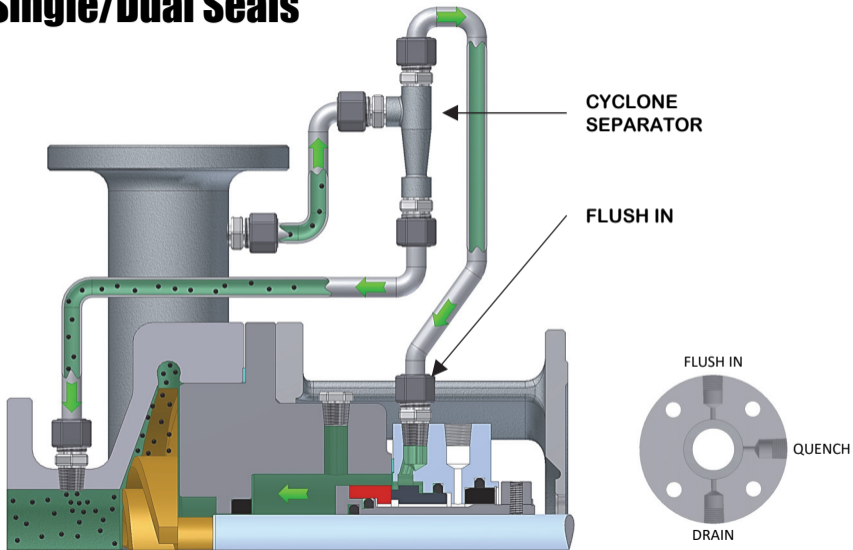

Discharge Through Separator Flush

Description: Plan 31 is recirculation from pump discharge through a CYCLONE SEPARATOR, sending clean flush into the seal chamber and heavy particles back to pump suction.

Objective: Dissipate seal generated heat and vent the seal chamber at start-up. Remove solids from the seal flush and seal chamber.

Advantages: Raises the pressure in the stuffing box while preventing erosion to the seal from abrasive processes. Works best for solids with a specific gravity twice the process fluid.

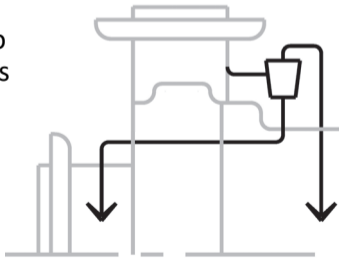



Single/Dual Seals

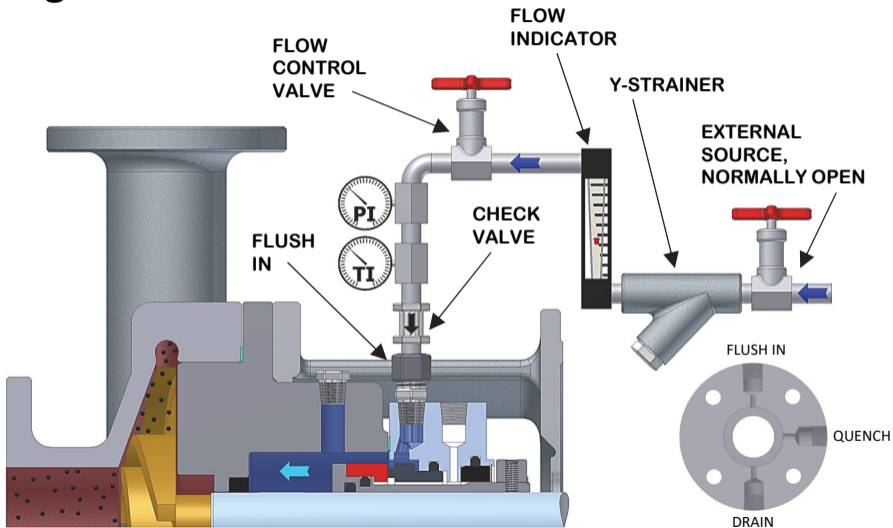

External Flush

Description: Plan 32 is injection of a cleaner or cooler fluid to the seal chamber from an external source, mixing into the process stream.

Objective: Isolate fluid in the seal chamber from process. Using a close-clearance throat bushing, the injected fluid can isolate the seal from a process with poor lubricity, high temperature, abrasive, dirty, corrosive, polymerizing, or oxidizing properties. To provide cooling to the seal.

Advantages: Seal life can be extended and vapor margin increased.

Caution: The cost of process dilution and/or water removal sometimes exceeds the savings created with longer seal life.

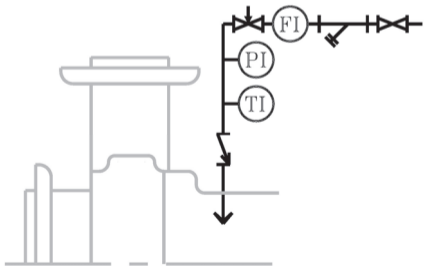



Single/Dual Seals

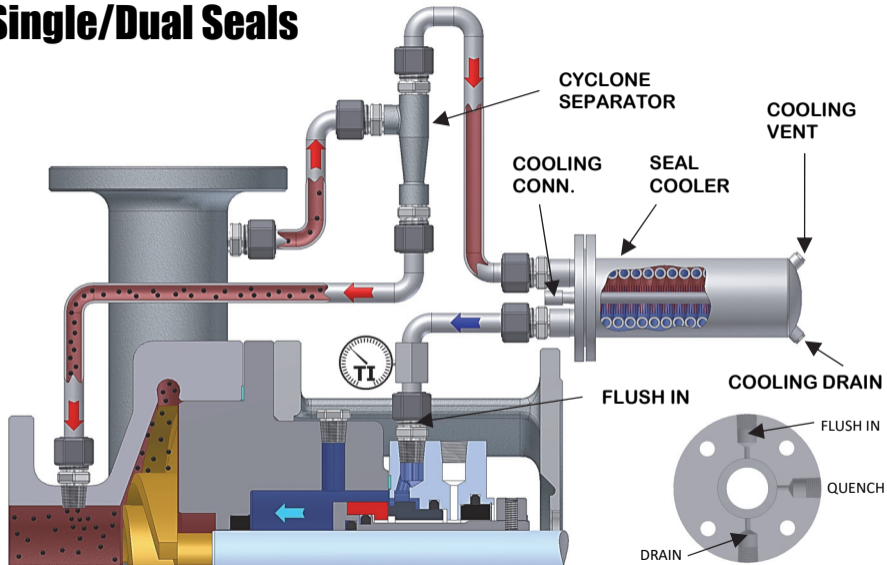

Discharge Through Separator and Flush Cooler

Description: Plan 41 is recirculation from pump discharge through a CYCLONE SEPARATOR, sending clean flush through a seal flush cooler, then into the seal chamber. Heavy particles are sent back to pump suction.

Objective: Cool and clean process being sent to the seal chamber, improving lubricity and increasing the vapor margin in the seal chamber. Reduce coking.

Advantages: Provides cooler and cleaner flush to the seal. When used with a close-clearance throat bushing, can raise the pressure in the seal chamber while preventing erosion to the seal from abrasive processes.

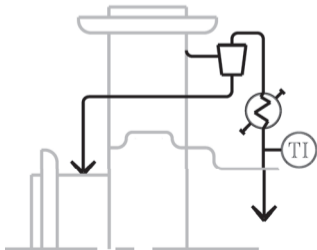



Dual Seals

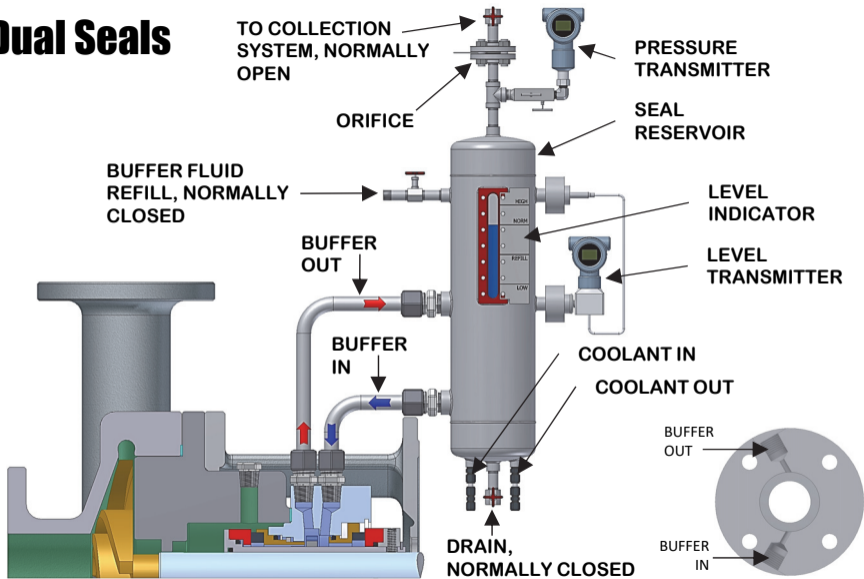



Buffer Liquid, External Reservoir

Description: Plan 52 is an external reservoir, typically NON-PRESSURIZED or maintained at a pressure less than the pressure in the seal chamber. Provides BUFFER fluid for the outer seal of an Arrangement 2 dual seal. Circulation provided by an internal pumping ring.

Objective: To reduce human and environmental contact in the event of a primary seal failure. Lubricate outer seal.

Advantages: No process contamination. Enhanced cooling available using cooling coils in the reservoir. Best for hazardous fluids, light hydrocarbons and vapors which are contained by a safety backup seal.

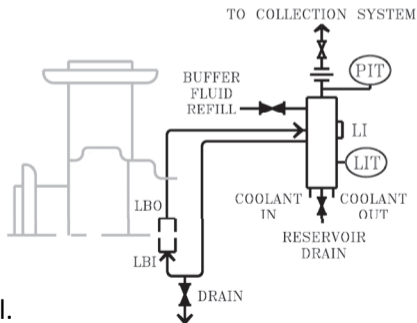



Dual Seals

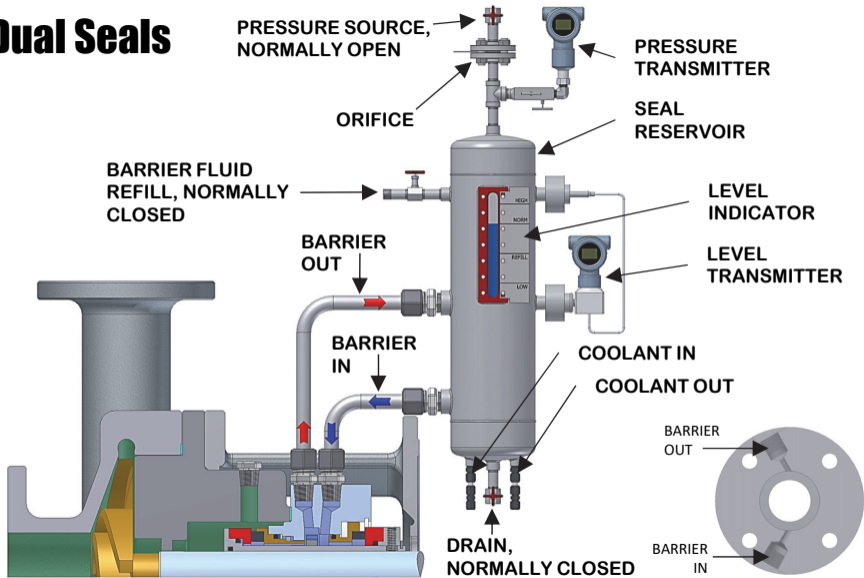

PLAN 53A

Pressurized Barrier Liquid, External Reservoir



Description: Plan 53A is an external reservoir, PRESSURIZED greater than the seal chamber pressure. Provides clean BARRIER fluid to an Arrangement 3 dual seal. Typically pressure is provided by nitrogen gas below 200 psig. Circulation provided by an internal pumping ring.

Objective: Provide favorable environment for long seal life. Ensure zero process emissions to environment.

Advantages: Prevents human and environmental contact with process. Enhanced cooling available using cooling coils. Best for toxic, hazardous, polymerizing, abrasive fluids and light hydrocarbons.

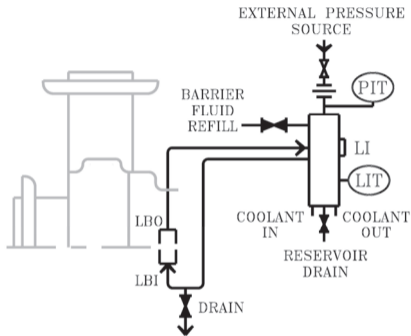



Dual Seals

PLAN 53B

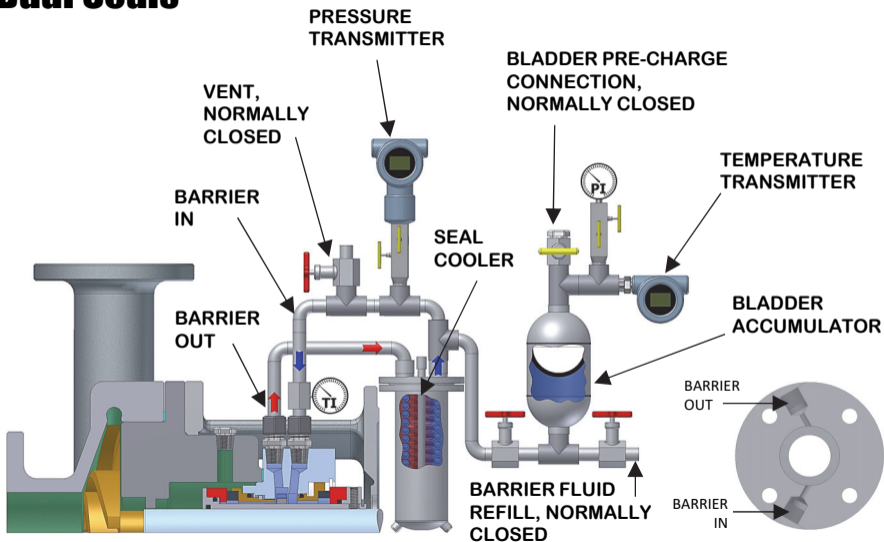

Pressurized Barrier Liquid, Bladder Accumulator



Description: Plan 53B utilizes a pre-pressurized BLADDER ACCUMULATOR isolating pressurized gas from barrier fluid and providing a PRESSURIZED system greater than the process pressure being sealed. Provides clean BARRIER fluid to an Arrangement 3 dual seal. Circulation provided by an internal pumping ring.

Objective: Same as Plan 53A, but handles higher pressures.

Advantages: Same as Plan 53A. Prevents pressurized gas entrainment. Additional cooling provided by finned tubing, forced air cooled or water cooled barrier cooler depending on heat load.

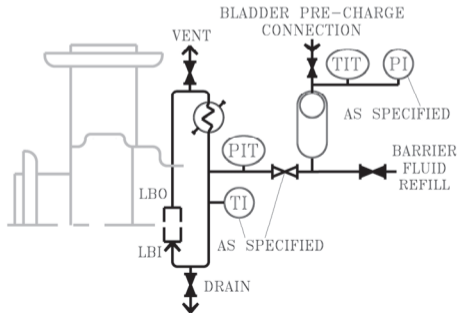



Dual Seals

PLAN 53C

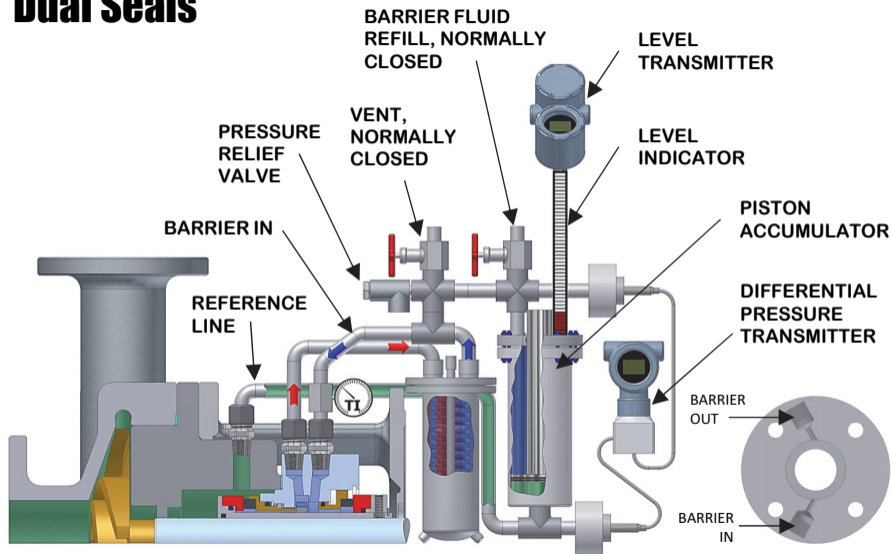



Pressurized Barrier Liquid, Piston Accumulator

Description: Plan 53C utilizes a reference line from the process in the seal chamber as a pressure source to a PISTON ACCUMULATOR. Provides a PRESSURIZED system greater than the process pressure being sealed, providing clean BARRIER fluid to an Arrangement 3 dual seal. Circulation provided by an internal pumping ring.

Objective: Same as Plan 53A, but will handle higher pressures and maintain a constant differential pressure above process pressure on the inner seal.

Advantages: Same as Plan 53B. Minimizes pressure reversals and maintains process seal stability.

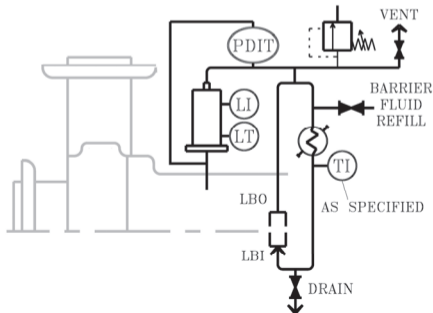



Dual Seals

PLAN 54

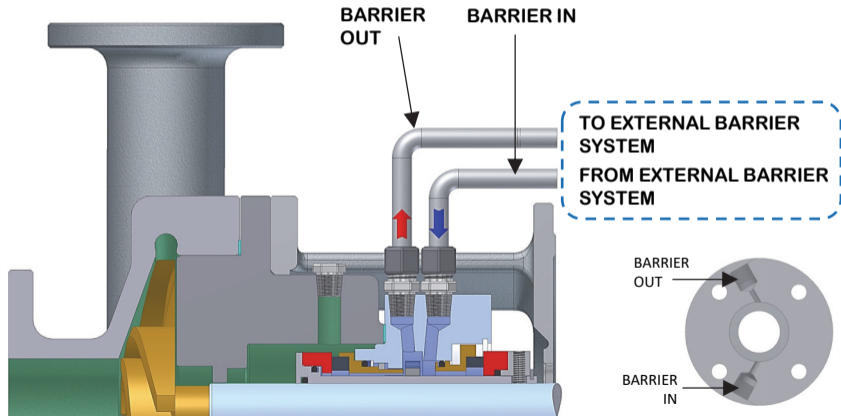

Pressurized Barrier Liquid, External System



Description: Plan 54 is an external system supplying clean BARRIER fluid to an Arrangement 3 dual seal at greater pressure than the process pressure being sealed. Pressure and circulation are provided for by an external pump or pressure system.

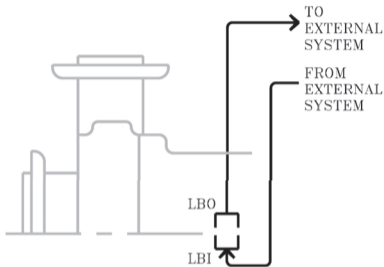

Objective: Same as Plan 53A and will provide constant pressure and flow through circulation system.

Advantages: Same as Plan 53A but provides excellent circulation and cooling. Can be used on multiple seals to reduce cost. The barrier fluid enters the seal and exits in a once in and once out fashion.



Dual Seals

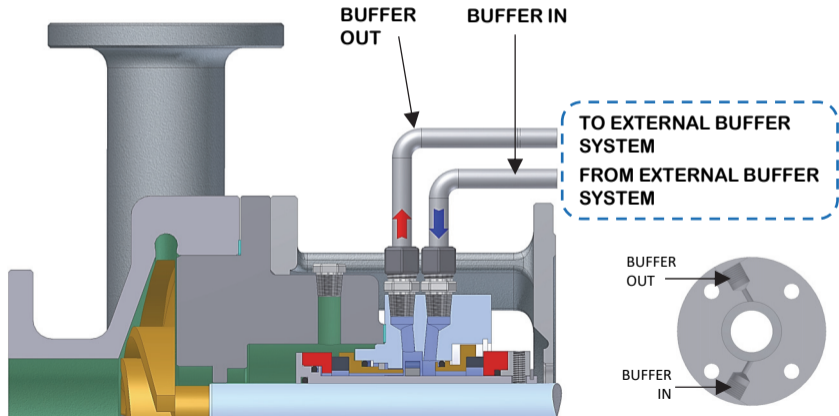



Buffer Liquid, External System

Description: Plan 55 is similar to Plan 54 except the system supplying clean BUFFER fluid is at less pressure than the process pressure being sealed, to an Arrangement 2 dual seal. No process contamination and improved cooling over Plan 52.

Objective: Same as Plan 52 and will provide constant pressure and flow through circulation system.

Advantages: Same as Plan 52 but provides excellent circulation and cooling. Can be used on multiple seals to reduce cost. The buffer fluid enters the seal and exits in a once in and once out fashion.

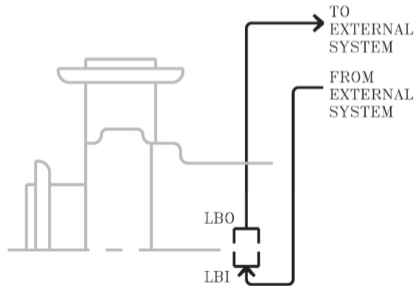



Single Seals

PLAN 62

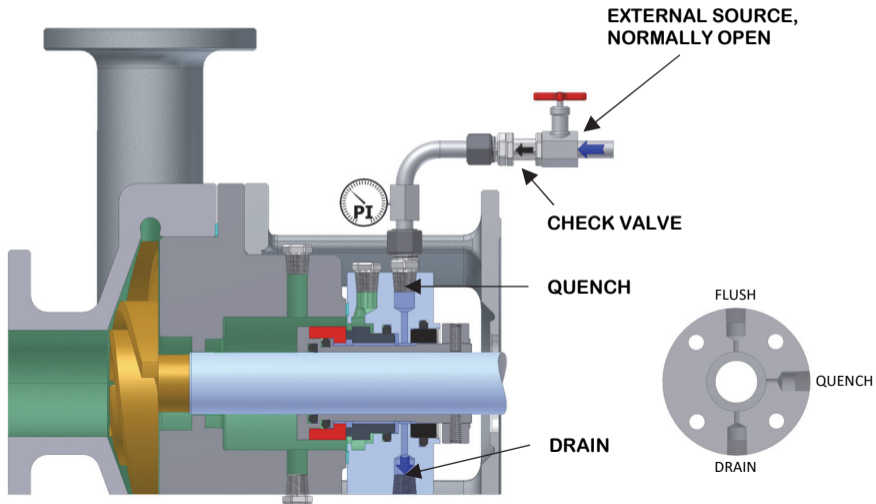



External Quench

Description: Plan 62 is an external source supplying quench (nitrogen, water, steam, etc.) on the atmosphere side of the seal. Typically used with a throttle bushing or auxiliary sealing device for containment.

Objective: To reduce oxidation, coking or crystallization of process accumulating on the atmospheric side of the seal.

Advantages: Utilizes miniscule flow rate of water or only a “whisper” of nitrogen or steam (2-4 psi). Can also provide some heating or cooling.

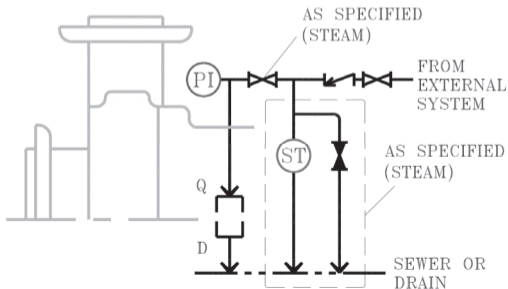



Single Seals

PLAN 65A

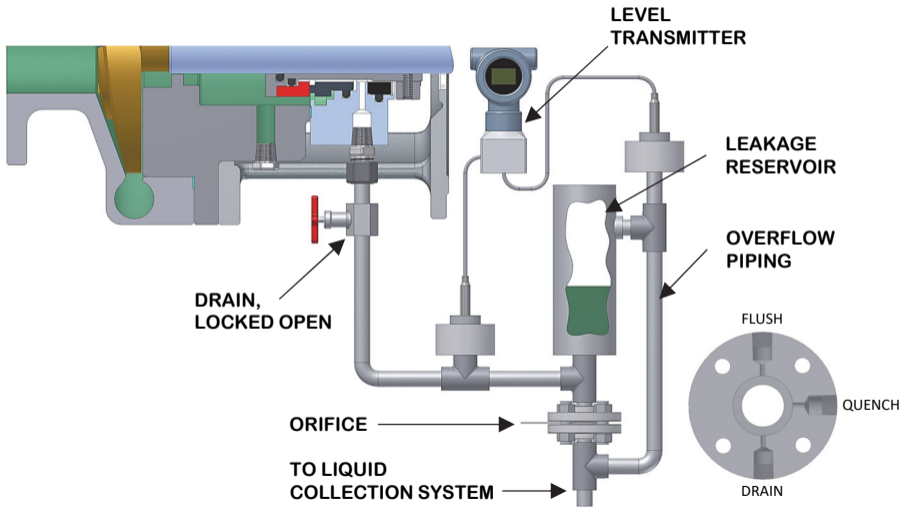



Excessive Liquid Leak Detection

Description: Plan 65A is a liquid leakage detection system measured by a level transmitter, arranged to set off an alarm when EXCESSIVE leakage occurs. Normally for Arrangement 1 single seals. The orifice downstream of the level transmitter is typically 1/4" located in a vertical piping leg. Includes a bypass around the orifice to prevent pressure build up. Use with close-clearance gland throttle bushing.

Objective: Safely control continuous draining to liquid collection system and alarm or shut pump down when excessive.

Advantages: Used for remote locations and critical processes. May be used with Plan 62 quench to reduce oxidation/coking build-up.

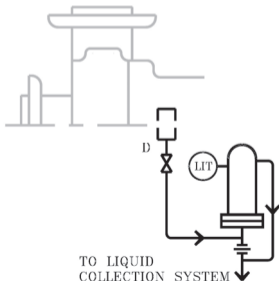



Single Seals

PLAN 65B

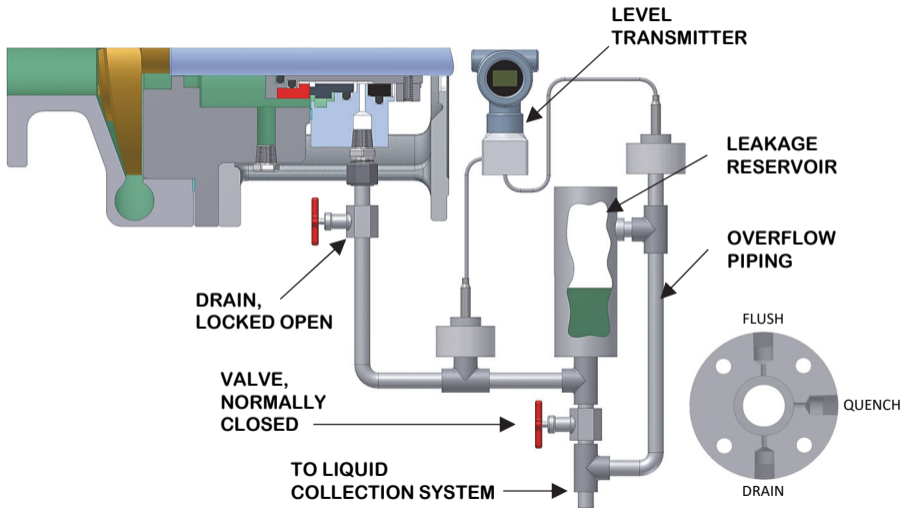



Total Liquid Leak Detection

Description: Plan 65B is a TOTAL liquid leakage detection system measuring accumulated liquid leakage. Normally for Arrangement 1 single seals. Seal leakage will collect in a containment vessel with a level transmitter and bypass line to prevent pressure build up. This plan will require that the operator periodically drain the collection vessel to allow for continuous operation. Use with close-clearance gland throttle bushing.

Objective: Safely detect seal failure and allow for shutting down the pump and containing seal leakage.

Advantages: Monitors ALL leakage to atmosphere. For remote locations and critical processes.

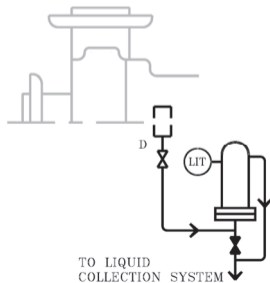



Single Seals

PLAN 66A

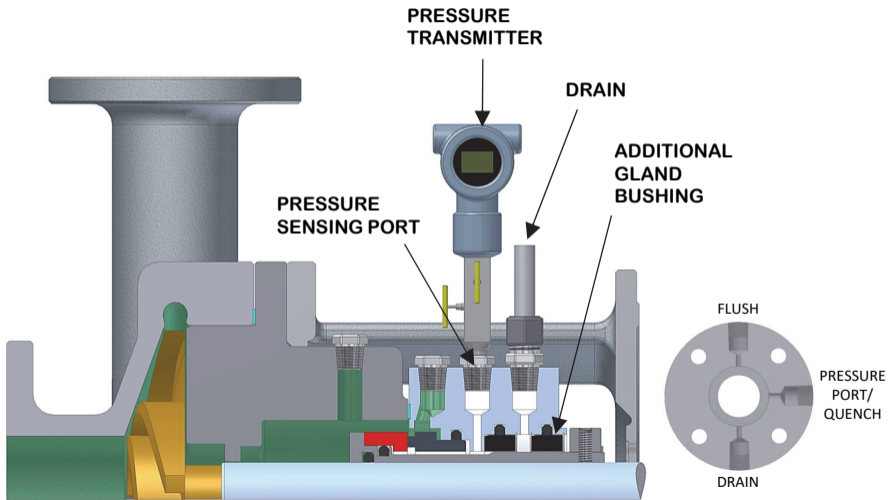



Leak Detection and Minimization

Description: Plan 66A is an external drain with an external pressure transmitter to detect high level leak rates. Normally for Arrangement 1 single seals. Pressure port and drain are separated by a gland bushing with an additional gland bushing on atmosphere side.

Objective: Detect seal failure early and minimize leakage past gland. Typically used on single seals in remote locations and critical processes.

Advantages: More efficient directing leakage to a drain than Plan 66B.

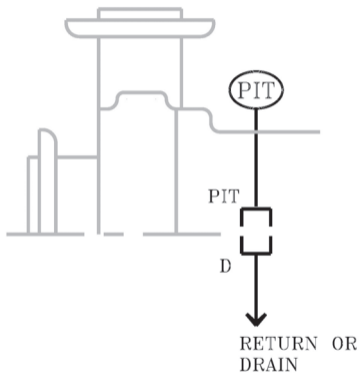



Single Seals

PLAN 66B

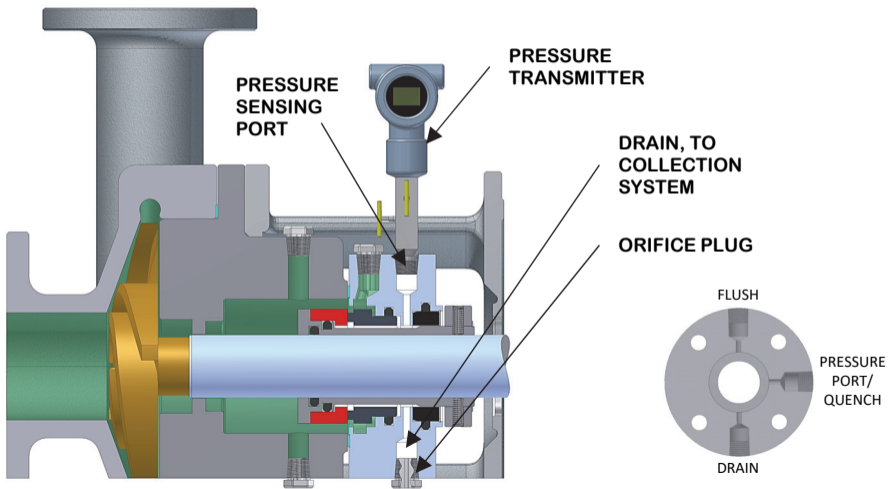

Leak Detection and Minimization (Single Bushing)



Description: Plan 66B is an external drain with an orifice plug and an external pressure transmitter to detect high level leak rates on atmosphere side of seal, utilizing a single gland bushing. Normally for Arrangement 1 single seals.

Objective: Same as Plan 66A.

Advantages: Can easily adapt to most existing seal glands.

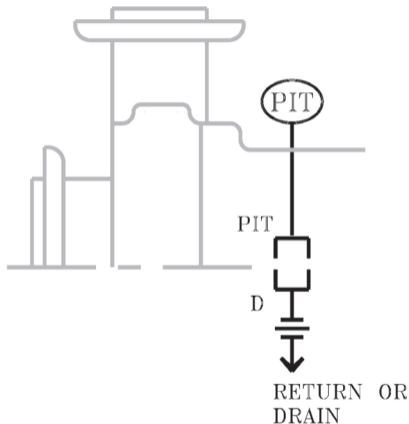



Dual Seals

PLAN 72

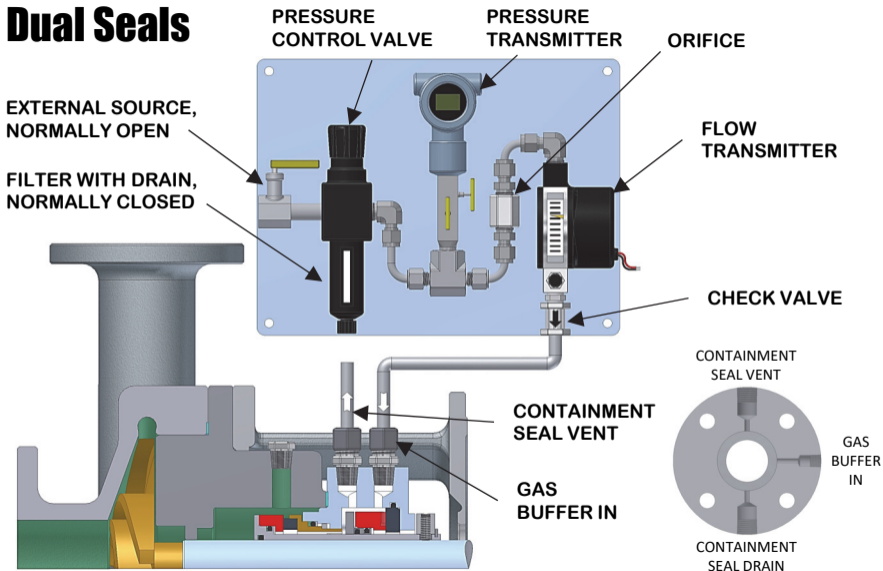

Secondary Containment, Buffer Gas



Description: Plan 72 is an external control system supplying a “whisper” of BUFFER gas (typically Nitrogen) at less pressure than the process pressure being sealed, to an Arrangement 2 dual gas seal, with a dry running containment seal. Used alone to dilute seal leakage or in conjunction with Plan 75 or 76 to help sweep seal leakage into a closed collection system.

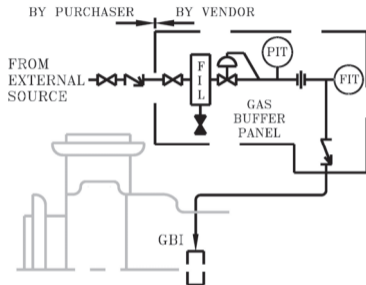

Objective: To reduce human and environmental contact in the event of a primary seal failure. Remove moisture, filter the gas and regulate the pressure to the seal.

Advantages: Zero to very low process emissions.



Dual Seals

PLAN 74

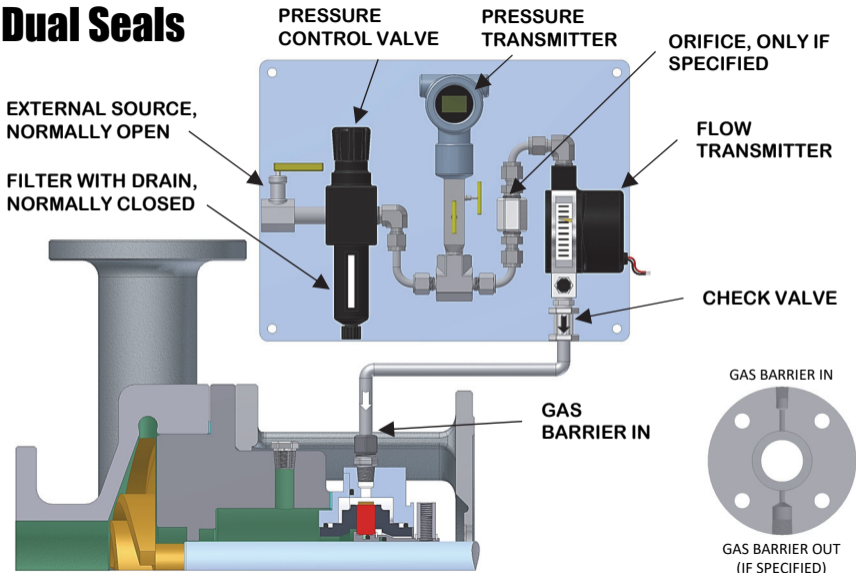

Pressurized Barrier Gas

Description: Plan 74 is an external control system supplying BARRIER gas (typically Nitrogen) at greater pressure than the process pressure being sealed, to an Arrangement 3 dual gas seal.

Objective: Prevent process from leaking to the atmosphere. Remove moisture, filter the gas and regulate the pressure to the seal. Best for hazardous, non-polymerizing, non-oxidizing fluids, light hydrocarbons and vapors.

Advantages: For processes that do not tolerate a liquid barrier. Can be used with LIFT OFF seal faces that generate no heat or wear and can have significantly increased seal life. Lower cost and maintenance than dual liquid systems.

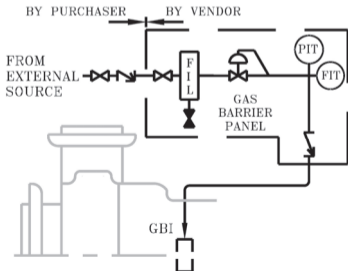



Dual Seals

PLAN 75

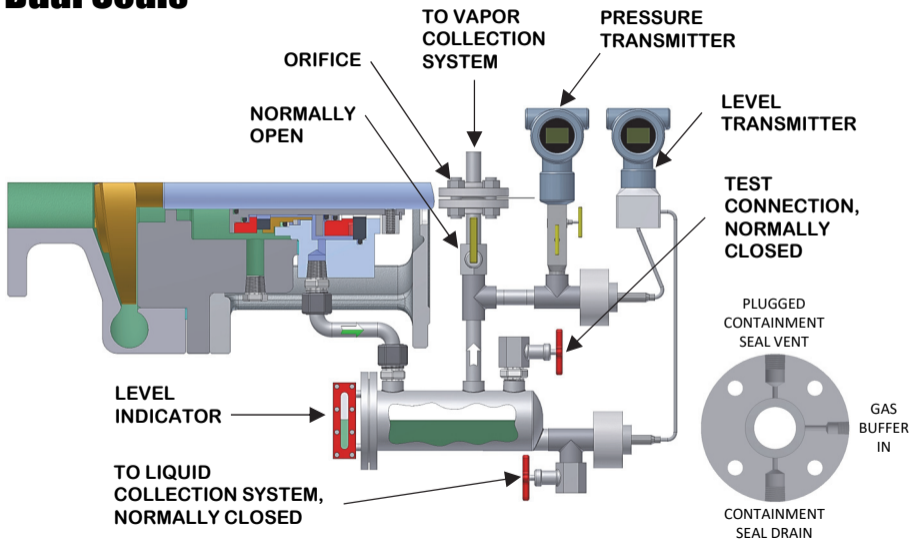

Secondary Containment, Condensing Leakage

Description: Plan 75 is a containment seal chamber which allows draining of condensing leakage on Arrangement 2 dual seals. The collection system is located below the seal chamber and uses an orifice and a pressure transmitter to detect high vapor leak rates. Typically used with contacting secondary containment seals.

Objective: Contain and vent leakage to collection system while monitoring leak rate. Orifice sized to allow maximum leakage and pressure alarm to shut down the pump if the leak rate is excessive.

Advantages: Best for processes that condense at ambient temperatures. Can be used with Plan 72 to sweep the leakage into the containment system. Lower cost and maintenance than dual liquid systems.

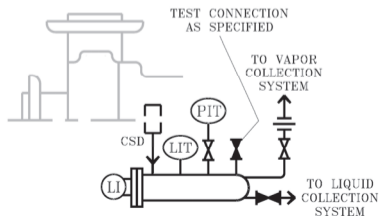



Dual Seals

PLAN 76

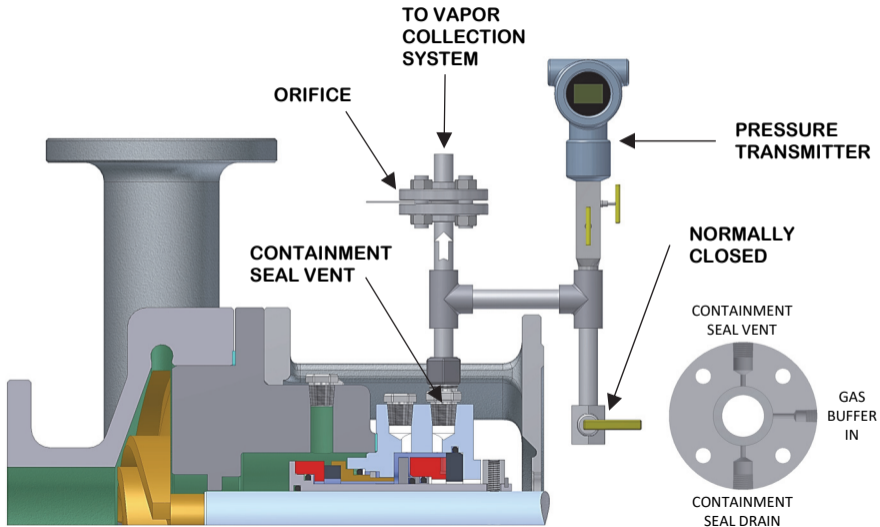

Secondary Containment, Non-Condensing Leakage

Description: Plan 76 is a containment seal chamber which allows venting of non-condensing leakage from an Arrangement 2 dual seal, to a flare or vapor recovery system.

Objective: Vent leakage to recovery while monitoring leak rate by sizing the orifice to allow maximum leakage. Pressure transmitter will shut down the pump if the leak rate is excessive.

Advantages: Best for processes that vaporize at ambient temperatures. Can be used with Plan 72 to sweep the leakage into the monitoring system. Is used with contacting or non-contacting containment seals. Lower cost and maintenance than dual liquid systems.

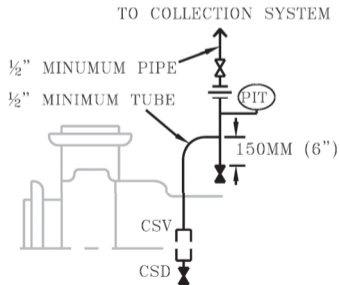



We are your Solution to Mechanical Seal Problems Through Innovative Engineering & Expert Technical Service

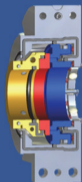

Split Seals



**Split Bushing
Seals**

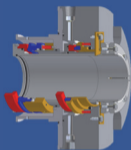

**High Pressure
Seals**

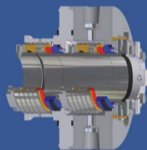

**High Temperature
Metal Bellows
Seals**

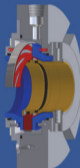

**Non-Contacting
Seals**

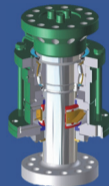

Mixer Seals

All plans and recommendations are intended as informative and educational per API 682. Use of these plans does not constitute a guarantee of improved seal life or warranty on the performance of mechanical seals and their systems. For any hazardous and dangerous applications consult PPC Engineering. PPC Mechanical Seals offers a lifetime guarantee on materials and workmanship for their products and seals.

www.ppcmechanicalseals.com
sales@ppcmechanicalseals.com
1-800-731-7325 • 1-225-356-4333
Baton Rouge, LA USA

©2023 PPC Mechanical Seals