

INSTALLATION INSTRUCTIONS:
 AFTER TIGHTENING GLAND BOLTS PUSH
 SET SCREW COLLAR AGAINST SETTING
 BUTTONS, THEN TIGHTEN SET SCREWS.
 SETTING BUTTON REMOVAL NOT NECESSARY

*.250 NPT, ϕ .125 FLUSH HOLE FOR
 SEAL SIZES UP TO 2.625
 .375 NPT, ϕ .156 FLUSH HOLE FOR
 SEAL SIZES 2.750 AND ABOVE

AS CAST VERSION

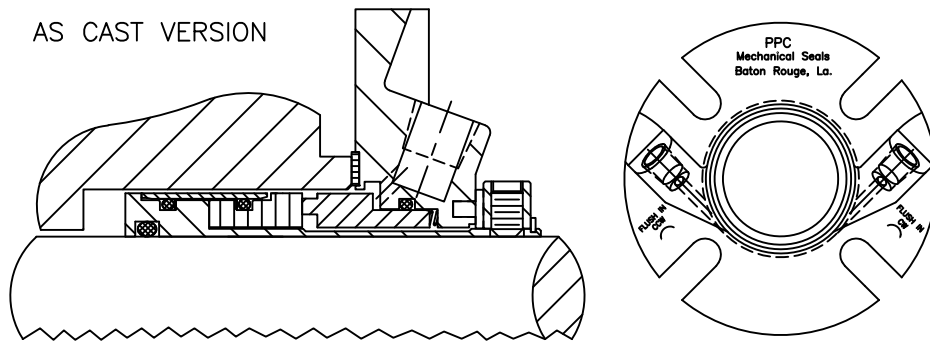

ITEM	DESCRIPTION
1	O-RING
2	O-RING
3	SHROUD
4	ROTARY FACE
5	SLEEVE
6	STATIONARY FACE
7	GASKET
8	GLAND
9	O-RING
10	SPRINGS
11	COLLAR
12	SPIROLOX
13	SETTING BUTTONS
14	SET SCREWS

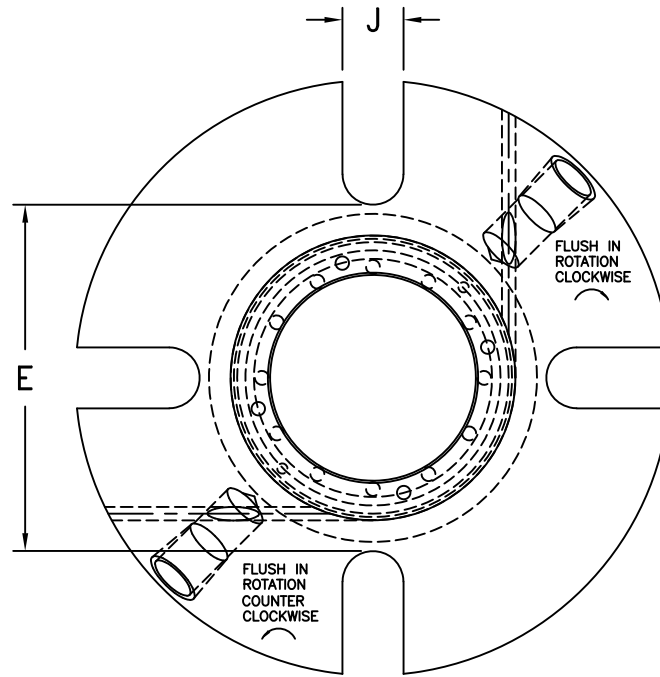
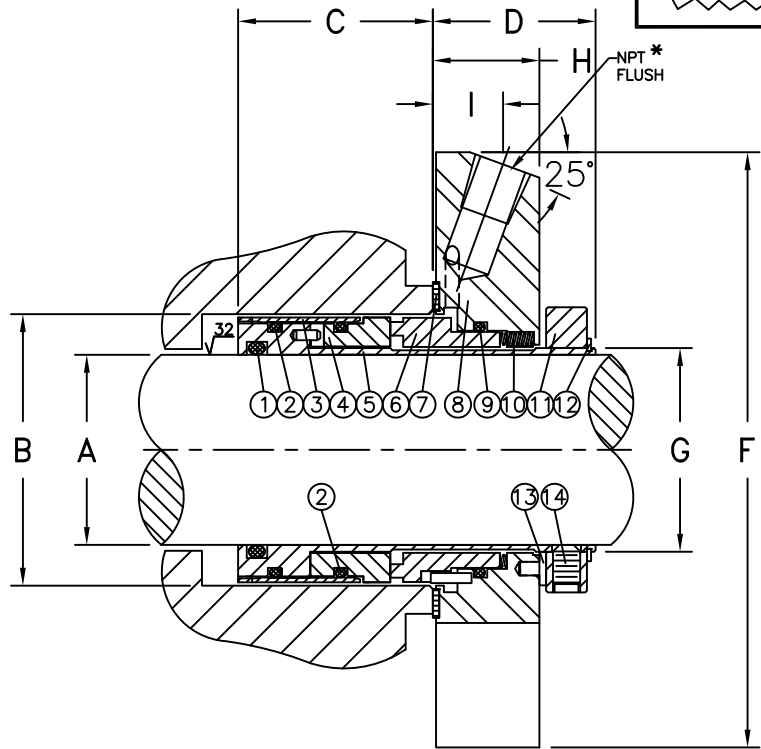

1500EHD MECHANICAL SEAL ASSEMBLY

A: SEAL SIZE		B (MIN)	B (MAX)	C	D	E	F	G	H	I	J	①	② 2 REQ'D	⑨
ENGLISH	METRIC													
1.000		1.625	2.010	1.79	1.50	2.31	4.11	1.125	.98	.71	.44	120	125	126
	28mm	1.750	2.040	1.79	1.50	2.44	4.24	1.250	.98	.71	.44	122	127	128
1.125		1.750	2.040	1.79	1.50	2.44	4.24	1.250	.98	.71	.44	122	127	128
	30mm	2.000	2.270	1.79	1.50	2.69	4.36	1.375	.98	.71	.56	124	130	130
1.250		2.000	2.270	1.79	1.50	2.69	4.36	1.375	.98	.71	.56	124	130	130
	32mm	2.000	2.270	1.79	1.50	2.69	4.36	1.375	.98	.71	.56	124	130	130
	33mm	2.000	2.430	1.79	1.50	2.75	4.36	1.500	.98	.71	.44	125	131	132
1.375		2.000	2.430	1.79	1.50	2.75	4.36	1.500	.98	.71	.44	126	131	132
	35mm	2.000	2.430	1.79	1.50	2.75	4.36	1.500	.98	.71	.44	126	131	132
	38mm	2.250	2.630	1.79	1.50	2.94	4.99	1.625	.98	.71	.56	222	135	135
1.500		2.250	2.630	1.79	1.50	2.94	4.99	1.625	.98	.71	.56	222	135	135
	40mm	2.375	2.690	1.79	1.50	3.06	4.99	1.750	.98	.71	.56	223	137	137
1.625		2.375	2.690	1.79	1.50	3.06	4.99	1.750	.98	.71	.56	223	137	137
	43mm	2.500	2.810	1.79	1.50	3.19	5.48	1.875	.98	.71	.56	224	139	139
1.750		2.500	2.810	1.79	1.50	3.19	5.48	1.875	.98	.71	.56	224	139	139
	45mm	2.625	2.940	1.79	1.50	3.31	5.49	2.000	.98	.71	.56	225	141	141
1.875		2.625	2.940	1.79	1.50	3.31	5.49	2.000	.98	.71	.56	225	141	141
	48mm	2.750	3.190	1.79	1.50	3.44	5.49	2.125	.98	.71	.56	226	143	143
	50mm	2.750	3.190	1.79	1.50	3.44	5.49	2.125	.98	.71	.56	226	143	143
2.000		2.750	3.190	1.79	1.50	3.44	5.49	2.125	.98	.71	.56	226	143	143
	53mm	2.875	3.440	1.79	1.50	3.81	5.99	2.250	.98	.71	.69	227	145	145
2.125		2.875	3.440	1.79	1.50	3.81	5.99	2.250	.98	.71	.69	227	145	145
	55mm	3.000	3.560	1.79	1.50	3.94	6.24	2.375	.98	.71	.69	228	147	147
2.250		3.000	3.560	1.79	1.50	3.94	6.24	2.375	.98	.71	.69	228	147	147
	60mm	3.125	3.590	1.79	1.50	4.06	6.24	2.500	.98	.71	.69	229	149	149
2.375		3.125	3.590	1.79	1.50	4.06	6.24	2.500	.98	.71	.69	229	149	149
2.500		3.250	3.810	1.79	1.50	4.19	6.48	2.625	.98	.71	.69	230	150	151
	65mm	3.375	4.070	1.79	1.50	4.75	7.62	2.750	.98	.71	.69	231	151	152
2.625		3.375	4.070	1.79	1.50	4.75	7.62	2.750	.98	.71	.69	231	151	152
2.750		3.750	4.190	2.14	1.80	4.88	7.74	3.000	1.20	.83	.69	232	152	237
	70mm	3.750	4.190	2.14	1.80	4.88	7.74	3.000	1.20	.83	.69	232	152	237
	75mm	4.000	4.440	2.14	1.80	5.06	8.00	3.250	1.20	.83	.69	234	153	239
3.000		4.000	4.440	2.14	1.80	5.06	8.00	3.250	1.20	.83	.69	234	153	239
3.125		4.125	4.565	2.14	1.80	5.25	8.12	3.375	1.20	.83	.69	235	154	240
	80mm	4.250	4.690	2.14	1.80	5.38	8.25	3.500	1.20	.83	.69	236	154	241
3.250		4.250	4.690	2.14	1.80	5.38	8.25	3.500	1.20	.83	.69	236	154	241
3.375		4.375	4.815	2.14	1.80	5.50	8.38	3.625	1.20	.83	.81	237	155	242
3.500		4.500	4.940	2.14	1.80	5.62	8.50	3.750	1.20	.83	.81	238	155	243
3.625		4.625	5.065	2.14	1.80	5.75	8.62	3.875	1.20	.83	.81	239	156	244
3.750		4.750	5.190	2.14	1.80	5.88	8.75	4.000	1.20	.83	.81	240	156	245
4.750		5.750	6.190	2.14	1.80	6.81	9.75	5.000	1.20	.83	.81	248	160	253

SHEET 1 OF 2

REV. C: CHANGED "B" (MIN DIM.) AND O-RING ITEM 2 FOR 30MM, 1.250 AND 32MM
 DIM FROM 1.875 TO 2.000 O-RING FROM 129 TO 130 02/25/2016 SMF/WWW (PAGE 1 OF 2)
 REV. B: CHANGED BOLT CIRCLE FROM 6.75 TO 5.44 B.C. 02-23-2004 BPD/WWW (PAGE 2 OF 2)
 REV. A: ADDED METRIC DIMENSIONS. 01-19-01 CLM/WWW

FILENAME: F:\CAD-DWG\INSTALL\00001855.DWG

PPC MECHANICAL SEALS BATON ROUGE, LA.			T-5145-C DWG. NO.
INITIALS	DATE		
DRAWN BY DA	07-07-99	COMPUTER AIDED DESIGN	
CHECKED BY WWW	07-07-99		

INSTALLATION INSTRUCTIONS:
 AFTER TIGHTENING GLAND BOLTS PUSH
 SET SCREW COLLAR AGAINST SETTING
 BUTTONS, THEN TIGHTEN SET SCREWS.
 SETTING BUTTON REMOVAL NOT NECESSARY

*.250 NPT, ϕ .125 FLUSH HOLE FOR
 SEAL SIZES UP TO 2.625
 .375 NPT, ϕ .156 FLUSH HOLE FOR
 SEAL SIZES 3.000 AND ABOVE

ITEM	DESCRIPTION	MATERIAL
1	O-RING	
2	O-RING	
3	SHROUD	
4	ROTARY FACE	
5	SLEEVE	
6	STATIONARY FACE	
7	GASKET	
8	GLAND	
9	O-RING	
10	SPRINGS	
11	COLLAR	
12	SPIROLOX	
13	SETTING BUTTONS	
14	SET SCREWS	

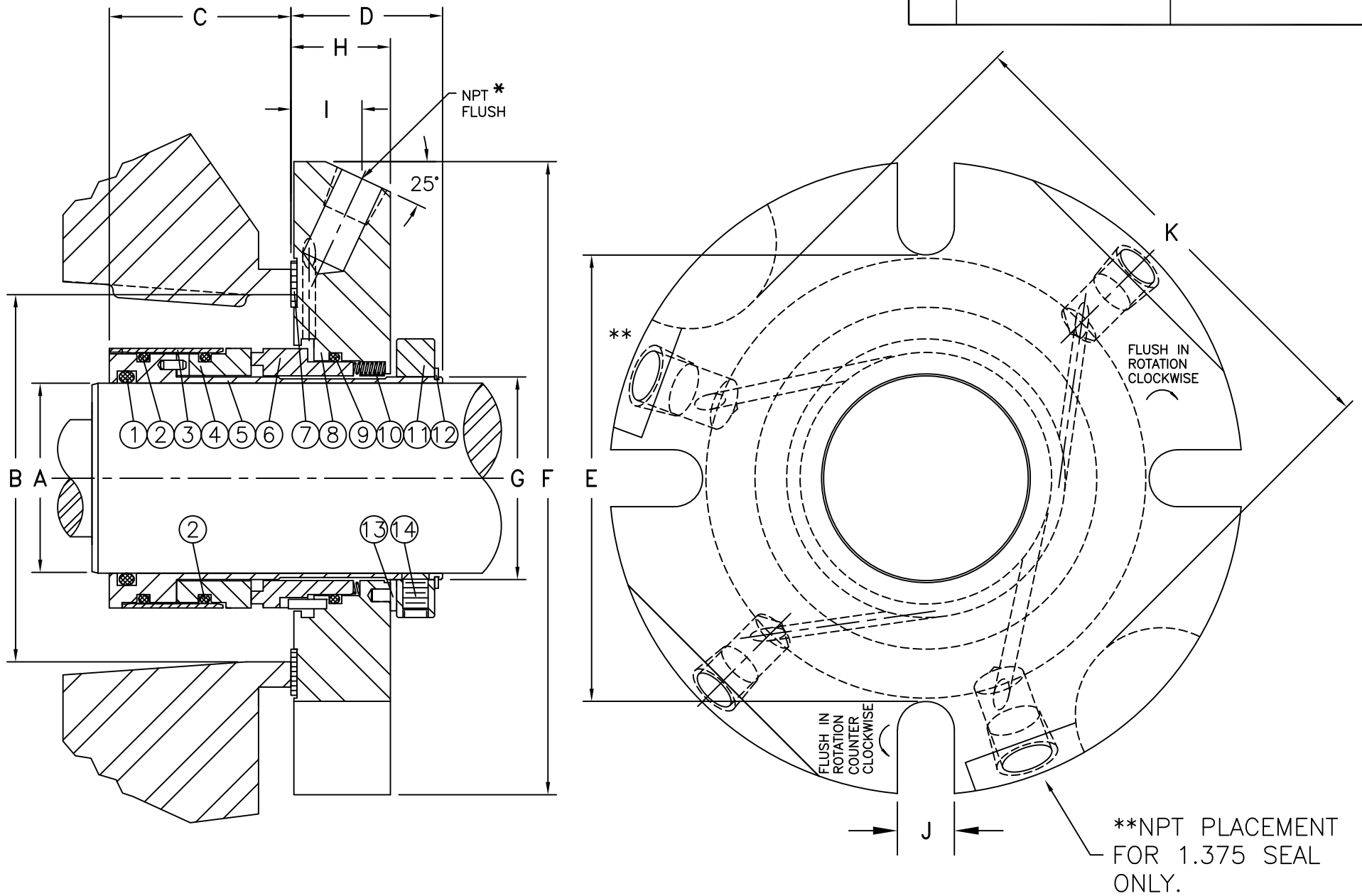

1500EHD+ MECHANICAL SEAL ASSEMBLY
 FOR OVERSIZE STUFFING BOX

A SEAL SIZE	B (MIN)	B (MAX)	C	D	E	F	G	H	I	J	K	①	② 2 REQ'D	⑨
1.125+	2.500	2.906	1.79	1.50	3.31	4.62	1.250	.98	.71	.44		122	127	128
1.375+	2.781	3.219	1.79	1.50	3.53	5.31	1.500	.98	.71	.44	4.12	126	131	132
1.750+	3.469	4.188	1.79	1.50	4.50	6.31	1.875	.98	.71	.56		224	139	139
1.875+	3.406	4.062	1.79	1.50	4.41	6.25	2.000	.98	.71	.56		225	141	141
2.125+	3.347	4.375	1.79	1.50	4.81	7.12	2.250	.98	.71	.69		227	145	145
2.500+	4.156	5.187	1.79	1.50	5.44	7.88	2.625	.98	.71	.69		230	150	151
2.625+	4.156	4.812	1.79	1.50	5.44	7.50	2.750	.98	.71	.56		231	151	152

SHEET 2 OF 2

REV. C: CHANGED "B" (MIN DIM.) AND O-RING ITEM 2 FOR 30MM, 1.250 AND 32MM
 DIM FROM 1.875 TO 2.000 O-RING FROM 129 TO 130 02/25/2016 SMF/WWW (PAGE 1 OF 2)
 REV. B: CHANGED BOLT CIRCLE FROM 6.75 TO 5.44 B.C. 02-23-2004 BPD/WWW (PAGE 2 OF 2)

FILENAME: F:\CAD-DWG\INSTALL\00001855.DWG

PPC MECHANICAL SEALS			T-5145-C DWG. NO.
BATON ROUGE, LA.			
INITIALS	DATE	COMPUTER AIDED DESIGN	
DRAWN BY DA	07-07-99		
CHECKED BY WWW	07-07-99		