

1.000" - 1.625"

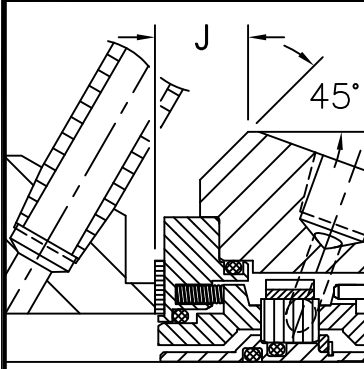

PUMP CONNECTION
CLEARANCE BEVEL

P-3F STANDARD BORE

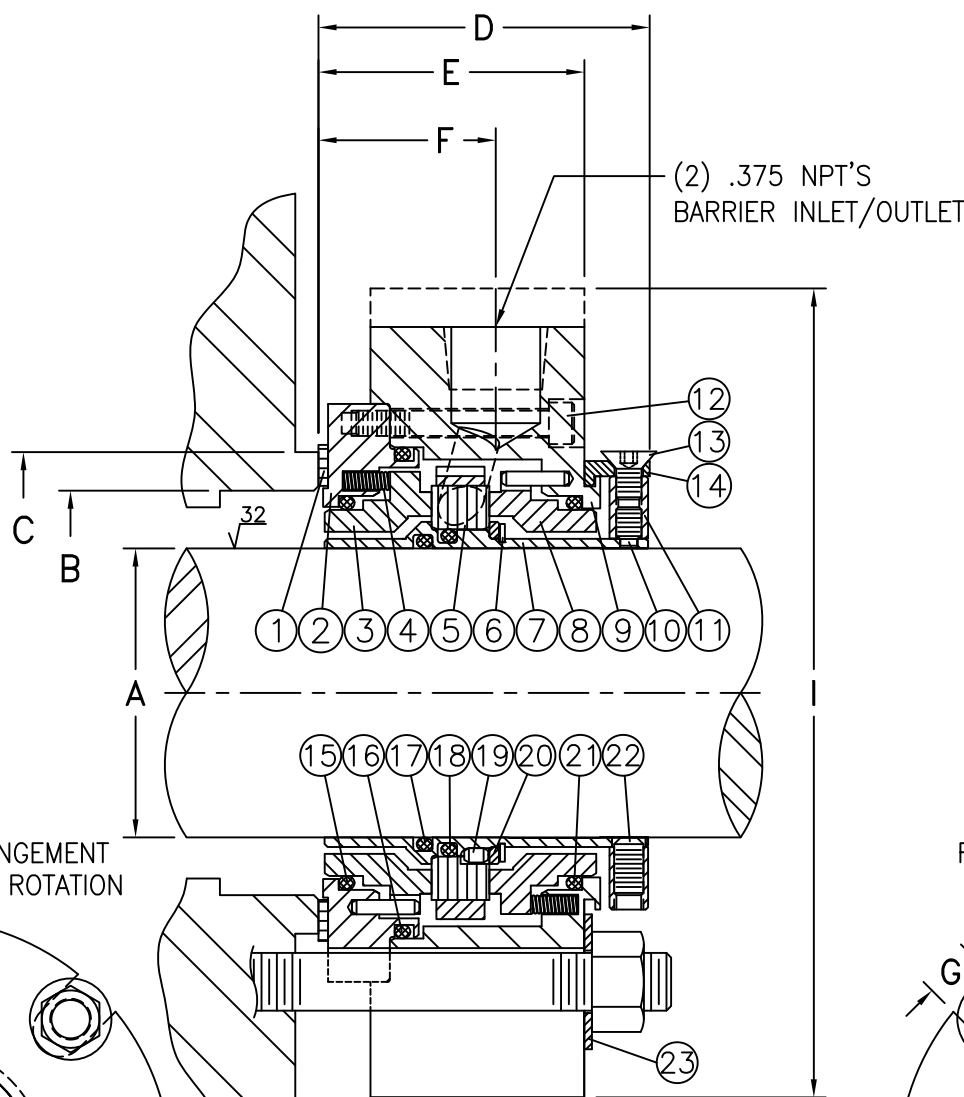

ITEM	DESCRIPTION
1	GASKET
2	GLAND ADAPTER
3	INBOARD STATIONARY FACE
4	SPRINGS
5	ROTARY FACE W/PUMPING BAND
6	RETAINING RING
7	SLEEVE
8	OUTBOARD STATIONARY FACE
9	GLAND
10	DOG POINT SET SCREWS
11	COLLAR
12	CAP SCREWS
13	FLAT HEAD CAP SCREWS
14	SETTING SPACERS
15	O-RING
16	O-RING
17	O-RING
18	O-RING
19	PINS/DOG POINT SET SCREWS
20	SPACER RING
21	O-RING
22	SET SCREWS
23	FLAT WASHERS

RECOMMENDED ARRANGEMENT
COUNTER-CLOCKWISE ROTATION

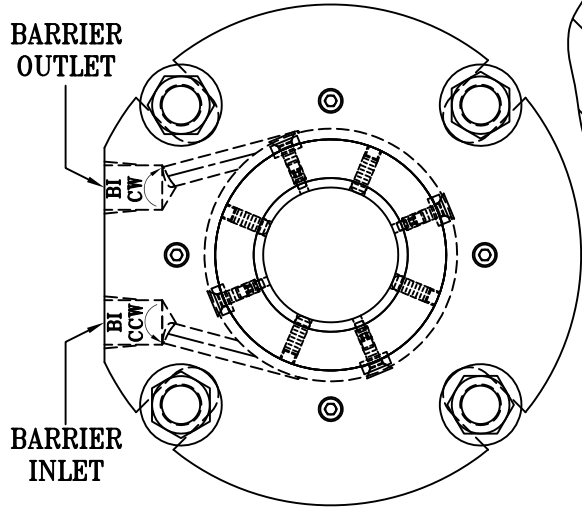

RECOMMENDED ARRANGEMENT
CLOCKWISE ROTATION

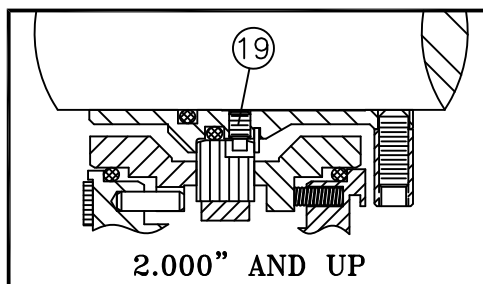
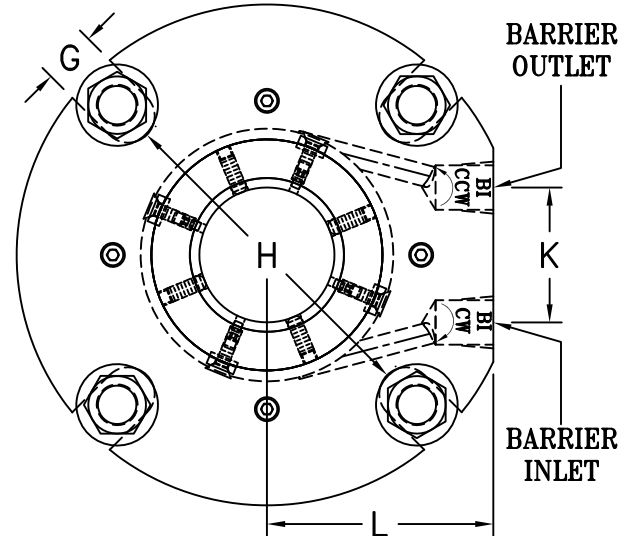

P-3F STANDARD BORE ARRANGEMENT

A	B min.	B max.	C min.	D	E	F	G	H	I	J	K	L
1.000	1.625	2.000	1.875	2.06	1.59	1.30 Δ	0.44	2.312	4.000	-	0.88	1.56 Δ
1.125	1.750	2.187	2.000	2.06	1.59	1.30 Δ	0.44	2.437	4.125	0.73	0.88	1.63 Δ
1.250	1.875	2.312	2.125	2.06	1.59	1.30 Δ	0.44	2.688	4.250	-	0.94	1.89 Δ
1.375	2.000	2.437	2.250	2.06	1.59	1.30 Δ	0.44	2.812	4.360	0.60	1.13	1.95 Δ
1.500	2.125	2.687	2.375	2.06	1.59	1.30 Δ	0.44	2.937	4.875	-	1.13	2.13 Δ
1.625	2.250	2.812	2.500	2.06	1.59	1.30 Δ	0.56	3.062	5.000	-	1.13	2.19 Δ
1.750	2.500	2.968	2.937	2.15	1.73	1.15	0.56	3.312	5.250	-	1.50	2.38
1.875	2.500	2.968	2.937	2.15	1.73	1.15	0.56	3.312	5.250	-	1.50	2.38
2.000	2.750	3.031	3.187	2.15	1.73	1.15	0.56	3.812	5.500	-	1.50	2.50
2.125	2.875	3.375	3.312	2.15	1.73	1.15	0.69	3.937	5.812	0.59	1.50	2.69
2.250	3.000	3.500	3.437	2.15	1.73	1.15	0.69	4.312	6.500	-	1.50	2.94
2.375	3.125	3.625	3.562	2.15	1.73	1.15	0.69	4.187	6.500	1.00	1.38	2.94
2.500	3.250	3.906	3.687	2.15	1.73	1.15	0.69	4.312	6.750	-	1.75	3.13
2.625	3.375	4.062	3.812	2.15	1.73	1.15	0.69	4.562	6.750	-	1.88	3.06
2.750	3.500	4.437	3.937	2.46	1.88	1.31	0.69	4.687	6.750	0.87	1.81	3.13
2.875	3.625	4.187	4.062	2.46	1.88	1.31	0.69	4.937	7.812	-	1.94	3.63
3.000	3.750	4.656	4.187	2.46	1.88	1.31	0.69	5.062	7.980	-	2.00	3.63
3.125	3.875	4.781	4.312	2.46	1.88	1.31	0.69	5.031	7.875	-	2.13	3.63
3.250	4.000	4.906	4.438	2.46	1.88	1.25	0.69	5.187	7.480	-	1.88	3.50
3.375	4.125	4.875	4.562	2.46	1.88	1.31	0.81	5.281	8.125	-	2.25	3.75
3.500	4.250	5.156	4.750	2.46	1.88	1.31	0.81	5.531	8.250	-	2.25	3.81
3.625	4.375	5.125	4.812	2.46	1.88	1.31	0.81	5.562	8.375	-	2.25	3.88
3.750	4.687	5.437	5.000	2.59	2.00	1.12	0.69	5.875	8.750	-	2.38	3.63
3.875	4.812	5.375	5.125	2.59	2.00	1.12	0.81	5.812	8.750	-	2.38	4.06
4.000	4.937	5.500	5.250	2.59	2.00	1.12	0.81	6.093	9.000	-	2.44	4.13
4.125	5.062	5.625	5.375	2.59	2.00	1.12	0.81	6.062	9.000	-	2.44	4.13
4.250	5.187	5.750	5.500	2.59	2.00	1.12	0.81	6.187	9.250	-	2.50	4.25
4.500	5.437	6.000	5.750	2.59	2.00	1.12	0.81	6.437	9.500	-	2.69	4.38
4.750	5.687	6.375	6.000	2.59	2.00	1.12	0.81	7.312	10.375 W/FLAT	-	3.00	4.75

P-3F/P-3F+ DUAL CARTRIDGE MECHANICAL SEAL

PPC MECHANICAL SEALS
BATON ROUGE, LA.

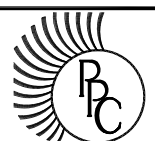

DWG. NO.
T-7743

INITIALS	DATE
DRAWN BY JRS	10-03-2013
CHECKED BY WWW	

COMPUTER
AIDED DESIGN

(2) .250 NPT'S
BARRIER INLET/OUTLET

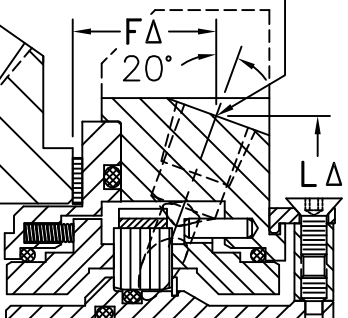

1.000" - 1.625"

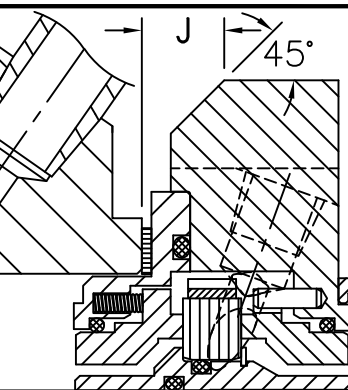

PUMP CONNECTION
CLEARANCE BEVEL

P-3F+ LARGE BORE

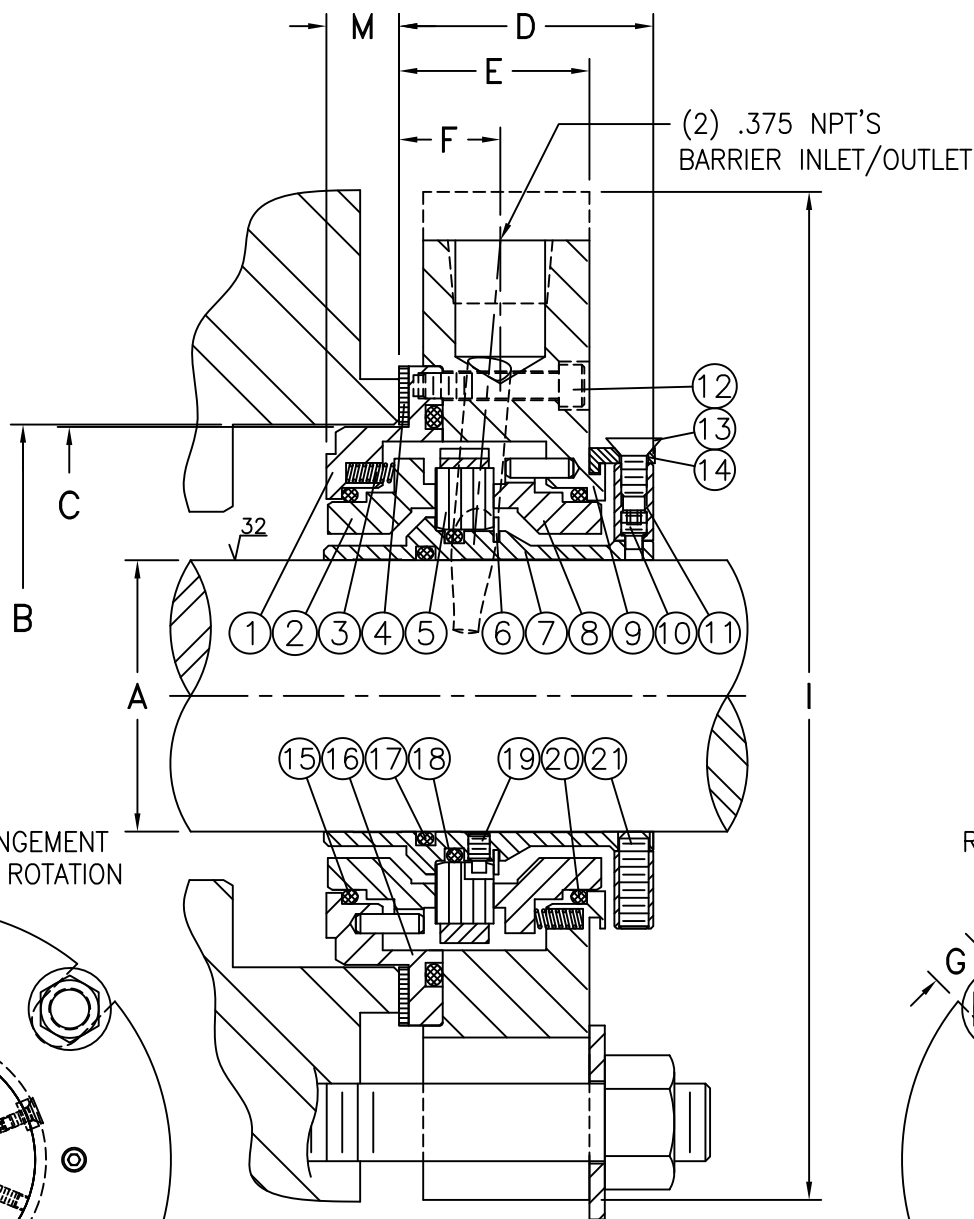

ITEM	DESCRIPTION
1	GLAND ADAPTER
2	INBOARD STATIONARY FACE
3	SPRINGS
4	GASKET
5	ROTARY FACE W/PUMPING BAND
6	RETAINING RING
7	SLEEVE
8	OUTBOARD STATIONARY FACE
9	GLAND
10	DOG POINT SET SCREWS
11	COLLAR
12	CAP SCREWS
13	FLAT HEAD CAP SCREWS
14	SETTING SPACERS
15	O-RING
16	O-RING
17	O-RING
18	O-RING
19	DOG POINT SET SCREWS
20	O-RING
21	SET SCREWS

RECOMMENDED ARRANGEMENT
COUNTER-CLOCKWISE ROTATION

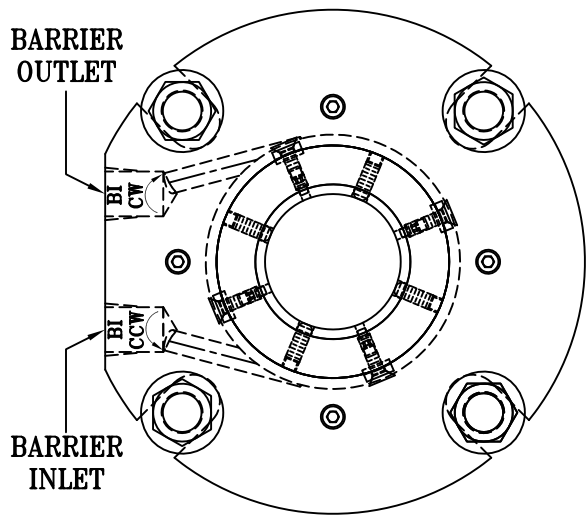

RECOMMENDED ARRANGEMENT
CLOCKWISE ROTATION

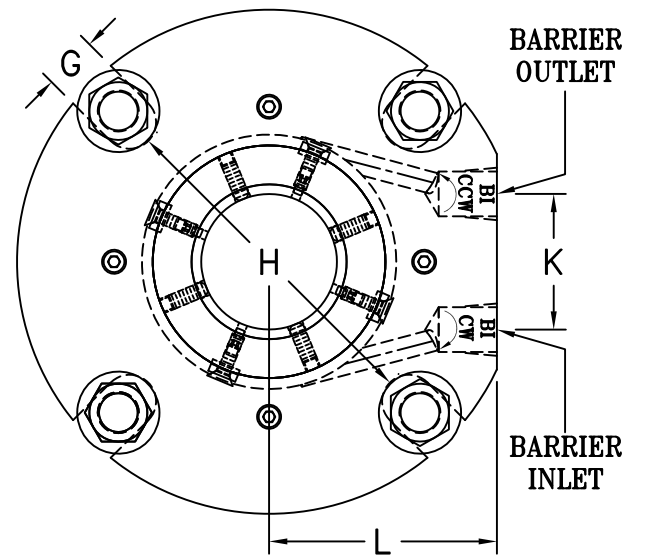

P-3F+ LARGE BORE ARRANGEMENT

A	B min.	B max.	C	D	E	F	G	H	I	J	K	L	M
1.125	2.625	2.906	2.594	1.68	1.27	0.93 Δ	0.44	3.312	5.437	-	1.38	2.19 Δ	0.44
1.375	2.875	3.218	2.844	1.68	1.27	0.93 Δ	0.44	3.500	5.375	0.53	1.50	2.00 Δ	0.44
1.750	3.500	4.000	3.469	1.68	1.26	0.68	0.56	4.406	6.500	0.44	1.75	2.94	0.44
1.875	3.500	4.000	3.469	1.68	1.26	0.68	0.56	4.406	6.500	0.44	1.75	2.94	0.44
2.125	3.625	4.125	3.594	1.68	1.26	0.68	0.69	4.438	7.125	0.44	1.63	3.34	0.44
2.500	4.500	5.125	4.469	1.87	1.45	0.87	0.69	5.375	8.000	-	1.13	3.56	0.25
2.625	4.625	5.031	4.594	1.68	1.26	0.68	0.69	5.375	8.000	-	1.88	3.75	0.44
2.750	4.750	5.125	4.500	2.41	1.82	1.03	0.69	5.375	8.000	-	1.50	3.81	0.65
3.000	5.000	5.625	-	2.46	1.88	1.09	0.69	6.437	8.375	-	2.00	3.94	-
3.750	5.750	6.437	-	2.59	2.00	1.12	0.69	7.437	9.375	0.67	2.50	4.31	-
4.750	6.750	7.687	-	2.59	2.00	1.12	0.69	8.125	11.000	-	4.69	4.50	-

P-3F/P-3F+ DUAL CARTRIDGE MECHANICAL SEAL

PPC MECHANICAL SEALS
BATON ROUGE, LA.

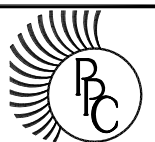

DWG. NO.
T-7743

INITIALS	DATE
DRAWN BY JRS	10-03-2013
CHECKED BY WWW	

COMPUTER
AIDED DESIGN