

ULTRASEAL 151Q
CARTRIDGE SEAL ASSEMBLY

A	B	C	D MIN	D MAX	E	F	G	H	I MAX	J
1.000	1.125	1.688	1.750	2.010	0.438	1.094	2.030	2.312	4.110	1.25
1.125	1.250	1.688	1.750	2.040	0.438	1.062	2.030	2.438	4.240	1.25
1.250	1.375	1.938	2.000	2.270	0.562	1.125	2.030	2.688	4.360	1.35
1.375	1.500	1.938	2.000	2.430	0.562	1.125	2.030	2.812	4.360	1.25
1.500	1.625	2.188	2.250	2.630	0.562	1.125	2.030	2.938	4.980	1.25
1.625	1.750	2.312	2.375	2.690	0.562	1.125	2.030	3.062	4.990	1.25
1.750	1.875	2.438	2.500	2.810	0.562	1.188	2.030	3.188	5.480	1.25
1.875	2.000	2.562	2.625	2.940	0.562	1.188	2.030	3.312	5.480	1.25
2.000	2.125	2.688	2.750	3.190	0.562	1.188	2.030	3.438	5.490	1.25
2.125	2.250	2.812	2.875	3.440	0.688	1.250	2.090	3.812	5.990	1.28
2.250	2.375	2.938	3.000	3.560	0.688	1.250	2.090	3.938	6.240	1.28
2.375	2.500	3.188	3.250	3.590	0.688	1.250	2.090	4.062	6.240	1.28
2.500	2.625	3.312	3.375	3.810	0.688	1.312	2.160	4.188	6.480	1.38
2.625	2.750	3.438	3.500	4.070	0.688	1.312	2.160	4.750	7.620	1.38
2.750	2.875	3.625	3.688	4.190	0.688	1.375	2.160	4.875	7.745	1.31
2.875	3.000	3.750	3.812	4.315	0.688	1.375	2.160	5.000	7.890	1.38
3.000	3.250	4.000	4.062	4.440	0.688	1.438	2.160	5.125	8.015	1.38
3.125	3.375	4.125	4.188	4.565	0.688	1.438	2.160	5.250	8.140	1.38
3.250	3.500	4.250	4.312	4.690	0.688	1.562	2.160	5.375	8.265	1.38
3.375	3.625	4.375	4.438	4.815	0.812	1.562	2.160	5.500	8.375	1.38
3.500	3.750	4.500	4.562	4.940	0.812	1.562	2.160	5.625	8.500	1.38
3.625	3.875	4.625	4.688	5.065	0.812	1.562	2.160	5.750	8.625	1.38
3.750	4.000	4.750	4.812	5.190	0.812	1.562	2.160	5.875	8.750	1.38

SHEET 1 OF 2
151Q STANDARD
BORE SIZES

REV. D: DIMENSION "J" ADDED. 08-10-2023 KLS/WWW

FILENAME: N:\CAD-DWG\INSTALL\00005534.DWG

ITEM	DESCRIPTION	MATERIAL
1	SLEEVE	
2	O-RING	
3	O-RING	
4	BELLOWS COLLAR	
5	BELLOWS	
6	GASKET	
7	INSERT HOLDER	
8	INSERT	
9	GLAND	
10	O-RING	
11	SEAT	
12	BUSHING	
13	RETAINING RING	
14	COLLAR	
15	RETAINING RING	
16	SETTING SPACERS	

MFG:	<input type="checkbox"/> PUMP	EQUIP.
MODEL:	<input type="checkbox"/> COMPRESSOR	
SIZE:	<input type="checkbox"/> AGITATOR	
SERIAL NO:	<input type="checkbox"/> VERTICAL <input type="checkbox"/> OTHER	

CUSTOMER:	CUSTOMER
END USER:	
LOCATION:	
STOCK NO:	
USER TAG:	USER:

PRODUCT:	PRODUCT
NOTES:	
BARRIER FLUID: PLAN:	

TEMP:	SUCT PRESS:
SP GR:	DISC. PRESS:
V P:	BOX PRESS:
VISC:	RPM:

DESC:ULTRASEAL 151Q CARTRIDGE MECHANICAL SEAL		
SIZE:TYPICAL		
DR BY: KLS	DWG. NO. T-1978-D	
COMPUTER AIDED DESIGN	SCALE: 1 = 1	CH BY: WWW
	DATE: 01-20-2021	AP BY: JRS

PPC MECHANICAL SEALS
BATON ROUGE, LA.

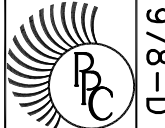

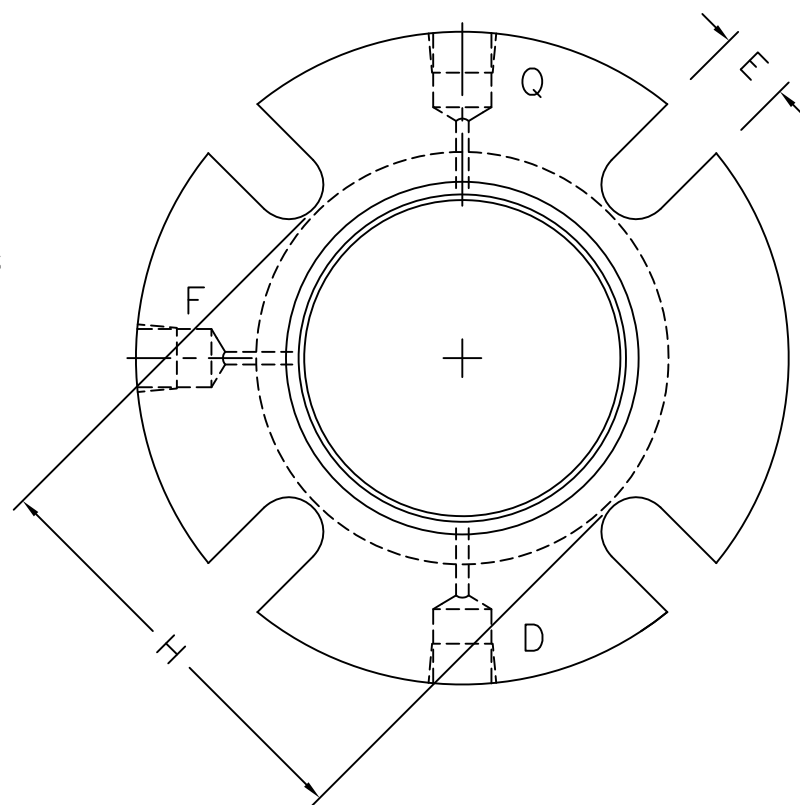
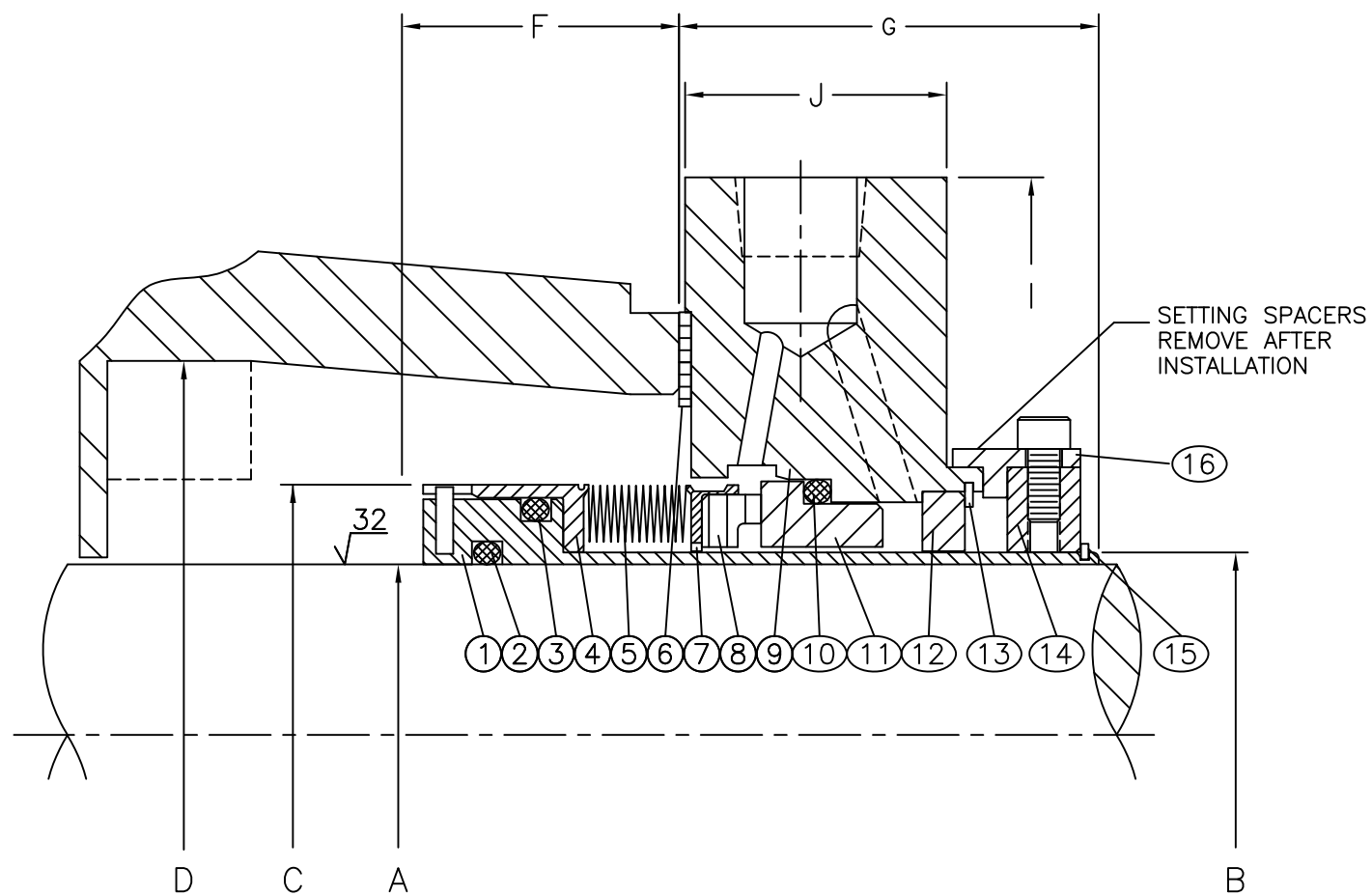

ITEM	DESCRIPTION	MATERIAL
1	SLEEVE	
2	O-RING	
3	O-RING	
4	BELLOWS COLLAR	
5	BELLOWS	
6	GASKET	
7	INSERT HOLDER	
8	INSERT	
9	GLAND	
10	O-RING	
11	SEAT	
12	BUSHING	
13	RETAINING RING	
14	COLLAR	
15	RETAINING RING	
16	SETTING SPACERS	

ULTRASEAL 151Q+
FOR BIG BORE STUFFING BOX

A	B	C	D MIN	D MAX	E	F	G	H	I MAX	J
1.375+	1.500	1.938	2.781	3.219	0.438	1.125	2.030	3.562	5.312	1.25
1.750+	1.875	2.438	3.469	4.188	0.562	1.188	2.030	4.500	6.312	1.25
1.875+	2.000	2.562	3.406	4.062	0.562	1.188	2.030	4.406	5.968	1.25
2.125+	2.250	2.812	3.437	4.375	0.688	1.250	2.090	4.812	7.125	1.28
2.625+	2.750	3.438	4.156	4.812	0.562	1.312	2.160	5.438	7.500	1.38

SHEET 2 OF 2
151Q BIG BORE SIZES

REV. D: DIMENSION "J" ADDED. 08-10-2023 KLS/WWW

MFG:		<input type="checkbox"/> PUMP	EQUIP.
MODEL:		<input type="checkbox"/> COMPRESSOR	
SIZE:		<input type="checkbox"/> AGITATOR	
SERIAL NO:		<input type="checkbox"/> VERTICAL <input type="checkbox"/> OTHER	
CUSTOMER:		USER:	CUSTOMER
END USER:			
LOCATION:			
STOCK NO:			
USER TAG:			
PRODUCT:		PRODUCT	
NOTES:			
BARRIER FLUID:			
PLAN:			
TEMP:		SUCT PRESS:	
SP GR:		DISC. PRESS:	
V P:		BOX PRESS:	
VISC:		RPM:	
DESC:ULTRASEAL 151Q+ CARTRIDGE MECHANICAL SEAL			
SIZE:TYPICAL			
COMPUTER AIDED DESIGN		SCALE: 1 = 1	DR BY: KLS
		DATE: 01-20-2021	CH BY: WWW
			AP BY: JRS
PPC MECHANICAL SEALS			DWG. NO. T-1978-D
BATON ROUGE, LA.			

