

# Plan 02

**Description:** Plan 02 is a dead-ended seal chamber with no recirculation of flush fluid.

**Objective:** Often used with a jacketed seal chamber to control temperature in high temperature processes. Use only when adequate vapor margin is present in the seal chamber.

**Advantages:** Little to no maintenance. Process solids are not continuously introduced into seal chamber. Plan 62 with steam can provide additional heating or cooling and minimize coking on hot processes.

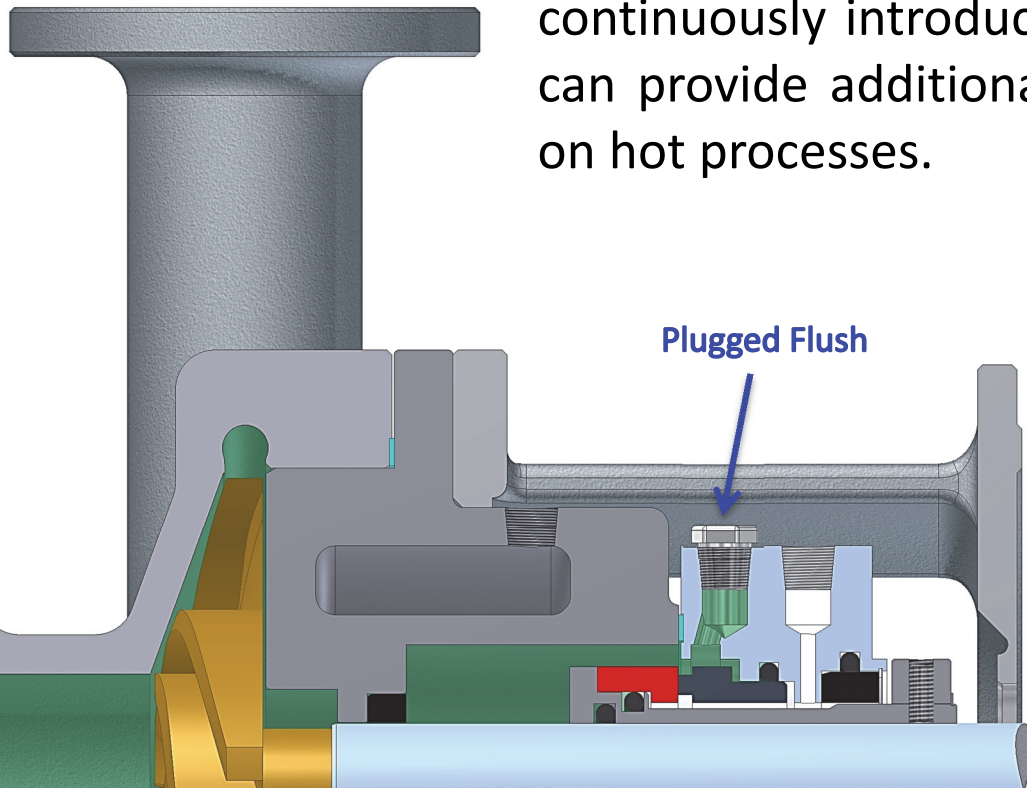

# Plan 03

**Description:** Plan 03 is a dead-ended seal chamber with an open throat, tapered seal chamber and flow modifiers to generate product circulation.

**Objective:** Dissipate seal generated heat, vent and drain the seal chamber, and aid in the removal of solids.

**Advantages:** Little to no maintenance. Process solids will not collect as they do in a traditional seal chamber. Use only when adequate vapor margin is present in the seal chamber. Plan 62 with steam can provide additional heating or cooling and minimize coking on hot processes.

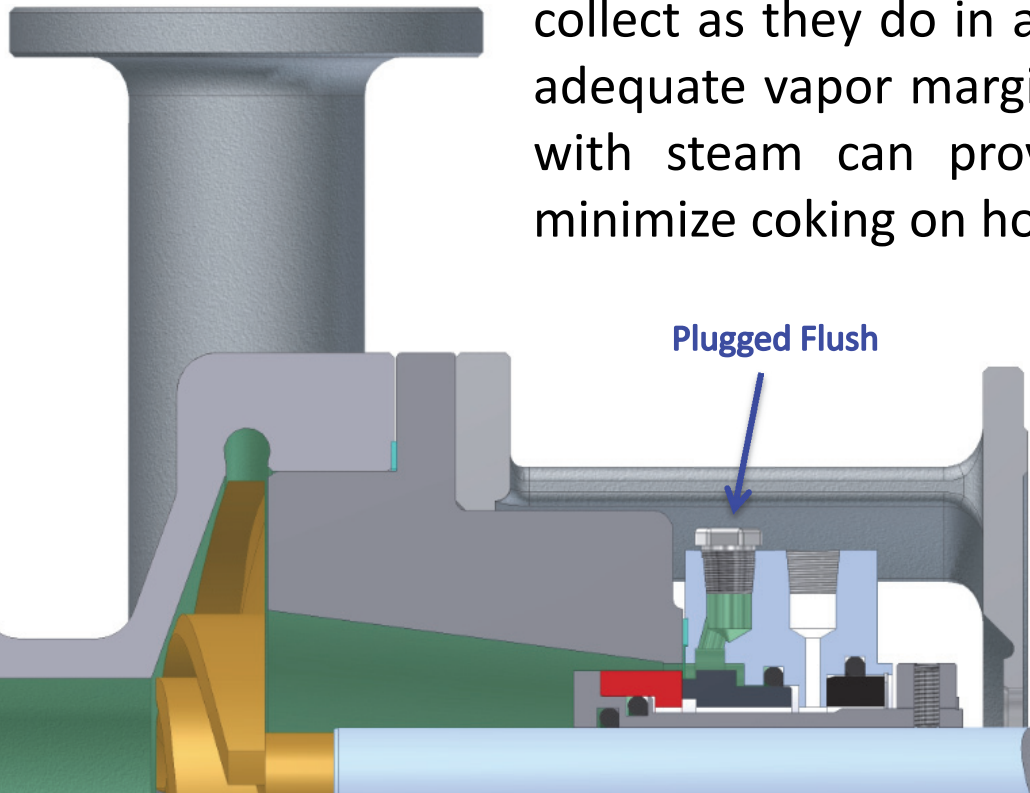

# Plan 11

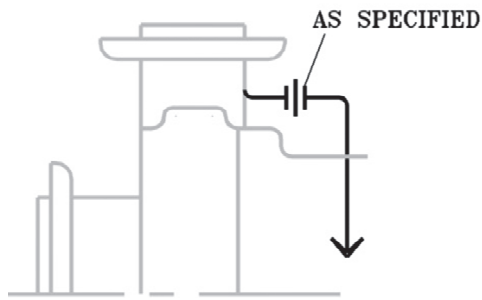

**Description:** Plan 11 is recirculation from pump discharge through an 1/8" minimum flow control orifice (when necessary), to the seal and back into the process through the pump seal chamber.

**Objective:** Dissipate seal generated heat, vent the seal chamber at start-up and increase the vapor margin in the seal chamber.

**Advantages:** When used with a close-clearance throat bushing, will raise the pressure in the seal chamber to maintain the process in the liquid state when cooling is not practical. Best for a clean, non-polymerizing process.

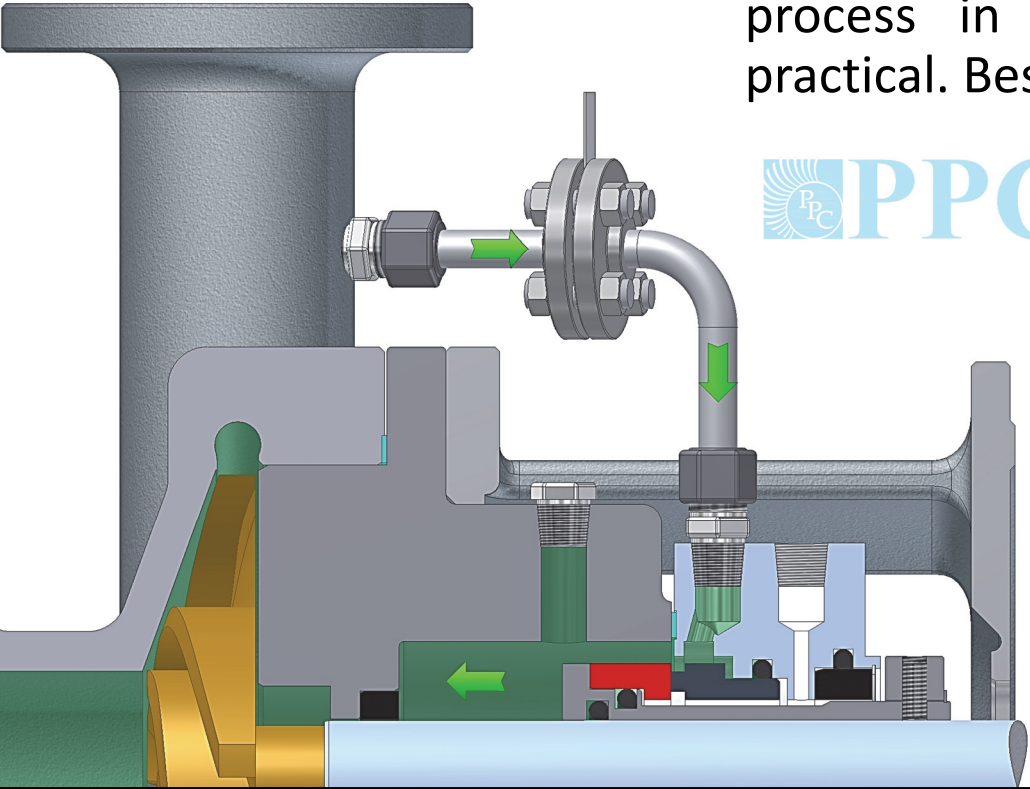

# Plan 01

**Description:** Plan 01 is an integral recirculation from the pump discharge to the seal chamber. This is an internal version of Plan 11. Recommended for clean process only.

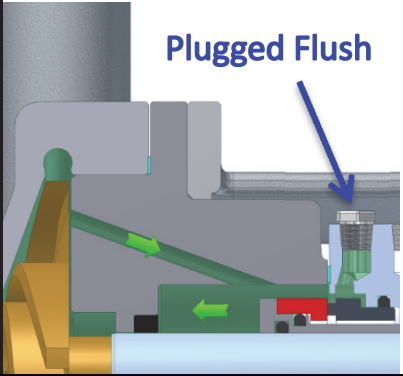

**Objective:** Same as Plan 11.

**Advantages:** No exposed plumbing around pump. Reduces risk of freezing or polymerization of process. Not recommended for vertical pumps.

# Plan 13

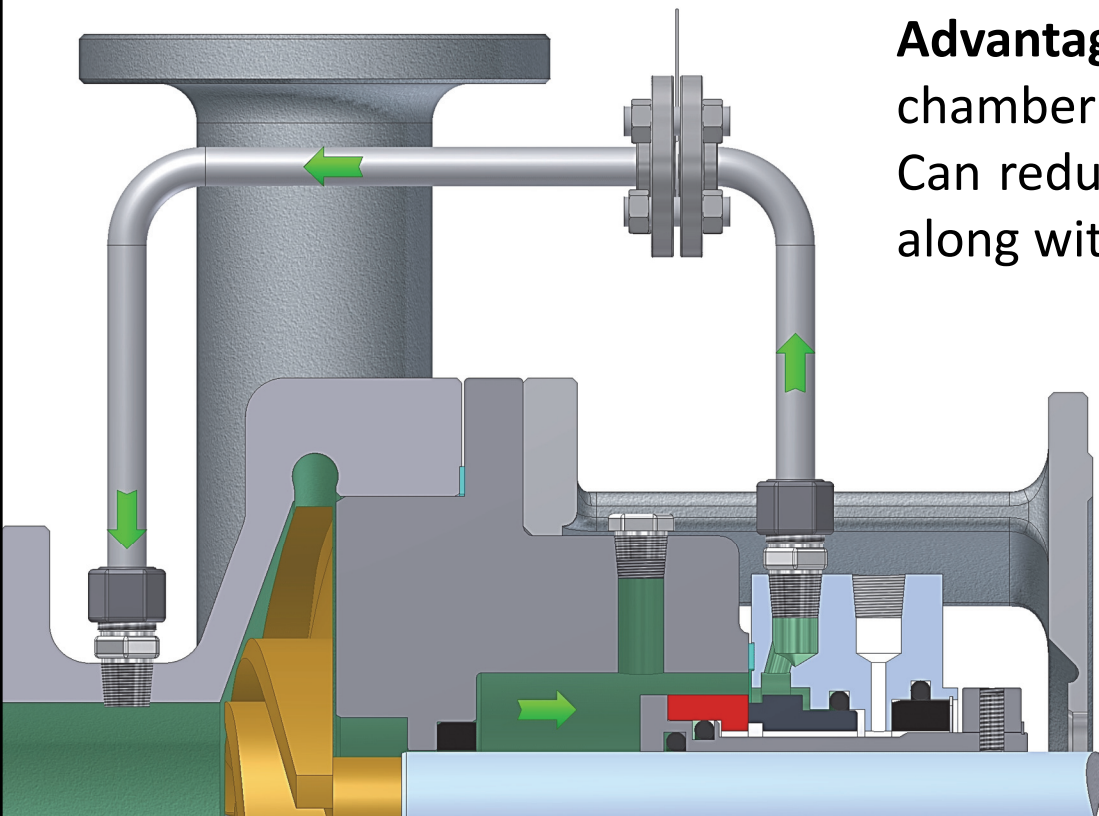
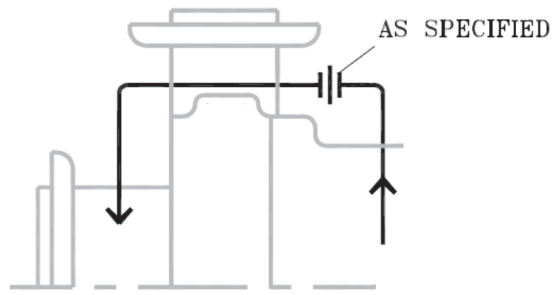

**Description:** Plan 13 is recirculation from the seal chamber or gland through an 1/8" minimum flow control orifice (when necessary), back to the pump suction. Standard flush plan for vertical pumps.

**Objective:** Remove seal generated heat and vent vertical pumps.

**Advantages:** Used in applications where the seal chamber pressure is greater than suction pressure. Can reduce the seal chamber pressure when used along with a close-clearance throat bushing.

# Plan 14

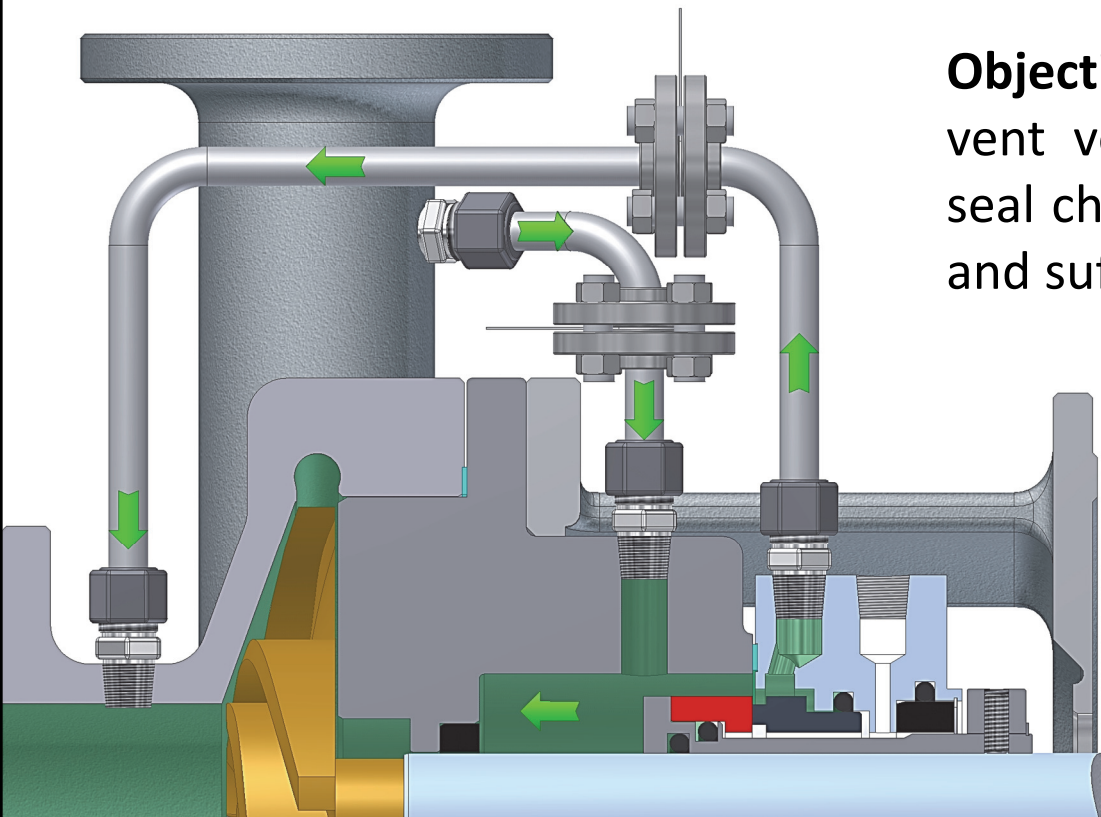
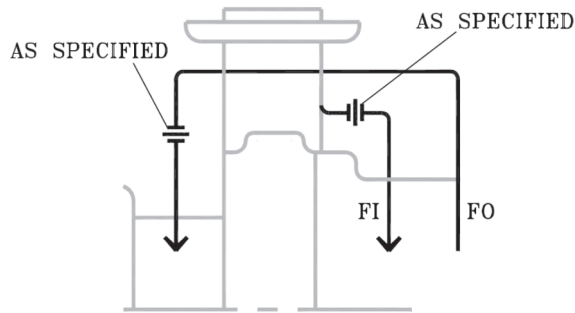

**Description:** Plan 14 is recirculation from pump discharge through a properly sized flow control orifice (when necessary), to the seal chamber and from the seal chamber through a properly sized flow control orifice (when necessary), to the pump suction. (A combination of Plan 11 and Plan 13)

**Objective:** Remove seal generated heat and vent vertical pumps while providing adequate seal chamber pressure for process vapor margin and sufficient fluid flow for cooling.

**Advantages:** Provides pressure and recirculation inside the seal chamber to avoid vaporizing liquids when used along with a close-clearance throat bushing and properly sized orifice.

# Plan 21

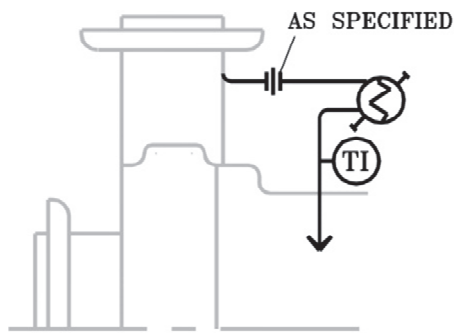

**Description:** Plan 21 is recirculation from pump discharge through an 1/8" minimum flow control orifice (when necessary), and seal flush cooler, then into the seal chamber.

**Objective:** Cool the process in the seal chamber, improving lubricity and increasing the vapor margin. Reduce coking.

**Advantages:** Provides cooling through a seal flush cooler. When used with a close-clearance throat bushing, it can raise

the pressure in the seal chamber.

Recommended over Plan 23 when used in viscous applications that may clog seal flush cooler.

**Note:** Plan 23 is the preferred plan due to high heat loads put on the seal flush cooler when using Plan 21.

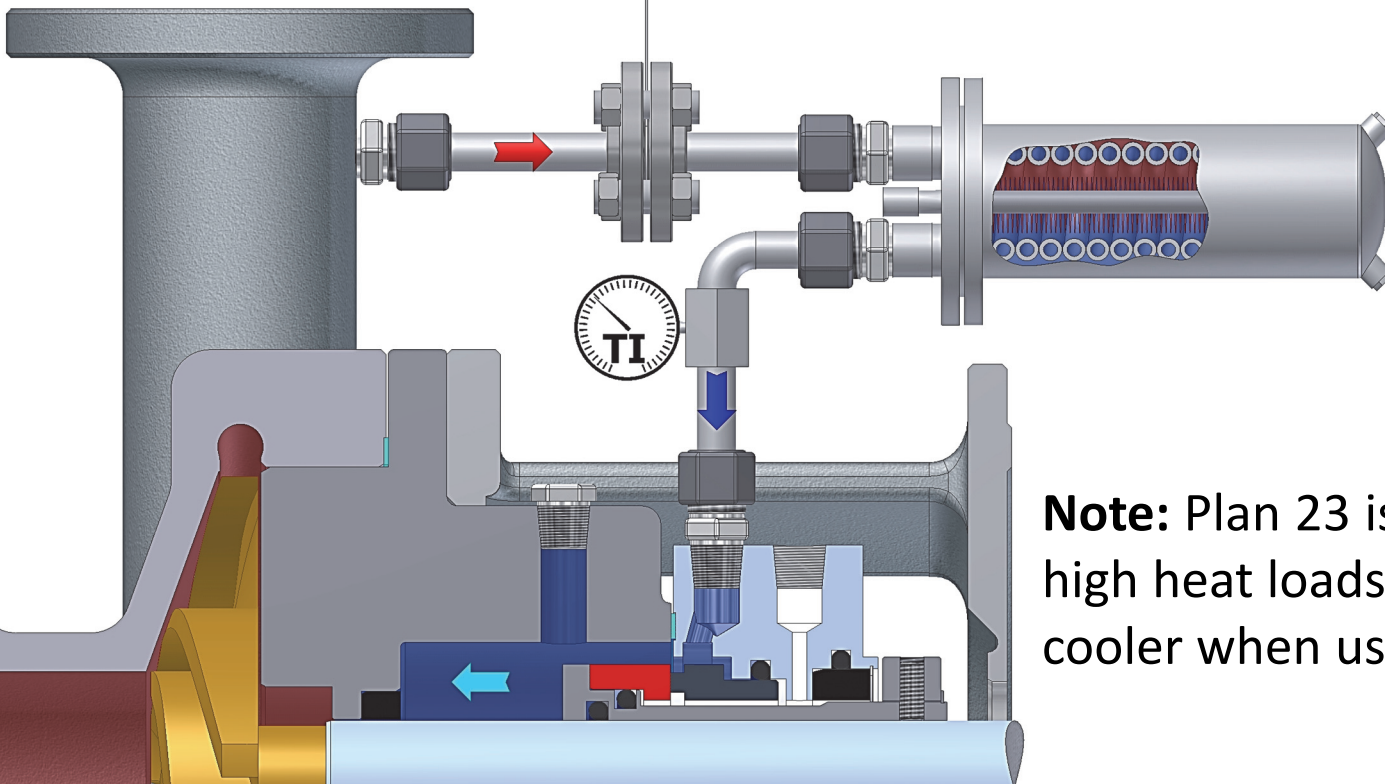

# Plan 23

**Description:** Plan 23 is recirculation of process fluid from the seal chamber, through a seal flush cooler, back into the seal chamber utilizing a pumping ring.

**Objective:** Cool process, improving lubricity and increasing the vapor margin in the seal chamber. Reduce coking.

**Advantages:** Has greater cooling efficiency than Plan 21 because it continuously recirculates the seal chamber fluid through the seal flush cooler. It decreases cooler duty, reduces cooler fouling and increases cooler life.

**Recommendation:** Vent tubing before pump start-up and use close-clearance throat bushing in seal chamber.

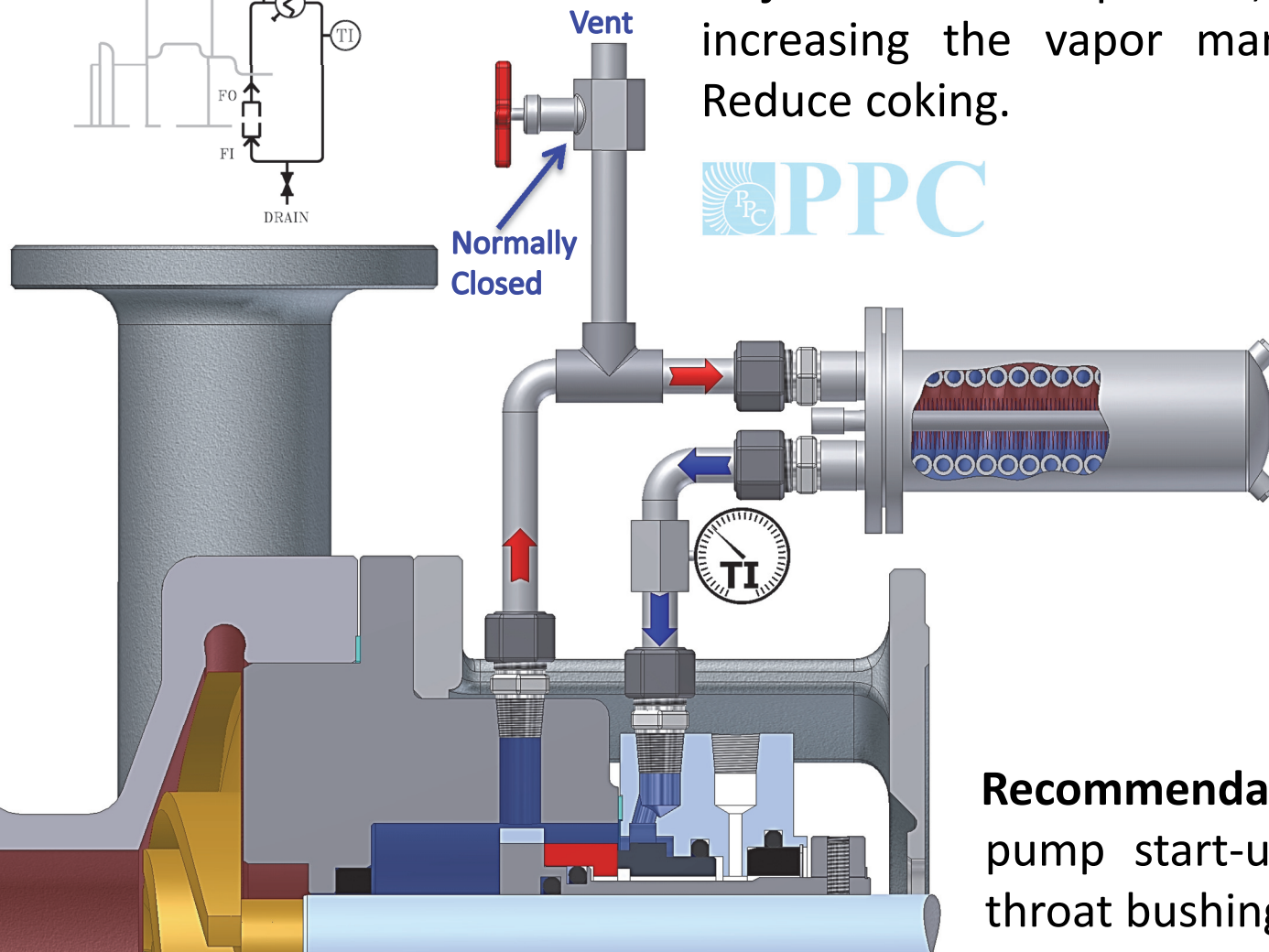
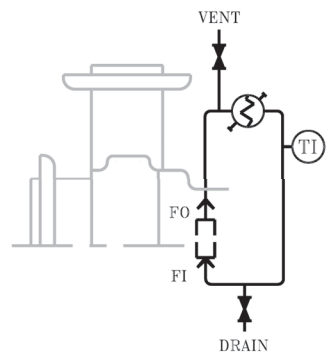

# Plan 31

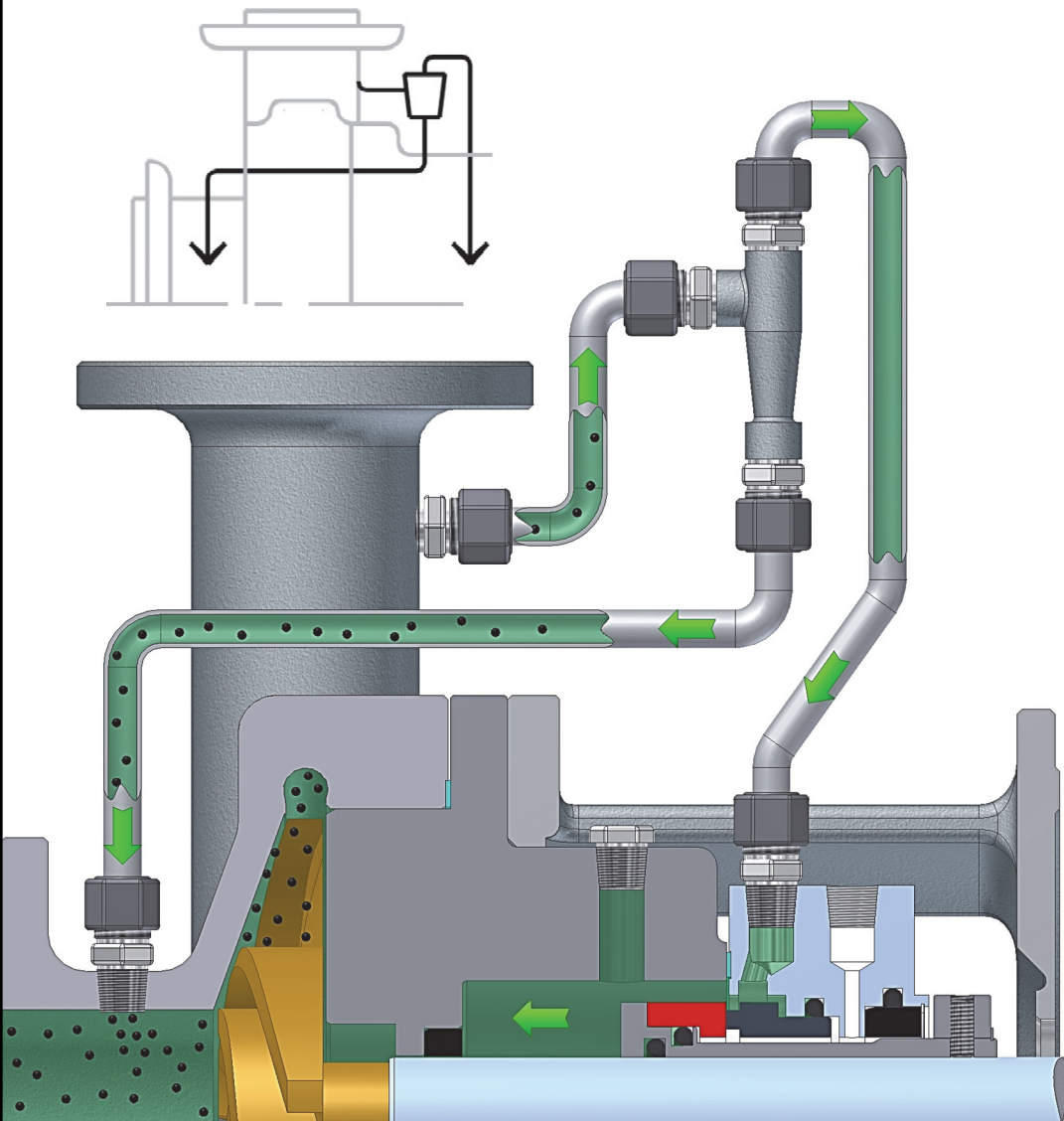

**Description:** Plan 31 is recirculation from pump discharge through a CYCLONE SEPARATOR, sending clean flush into the seal chamber and heavy particles back to pump suction.

**Objective:** Dissipate seal generated heat and vent the seal chamber at start-up. Remove solids from the seal flush and seal chamber.

**Advantages:** Raises the pressure in the stuffing box while preventing erosion to the seal from abrasive processes. Works best for solids with a specific gravity twice the process fluid.



# Plan 32

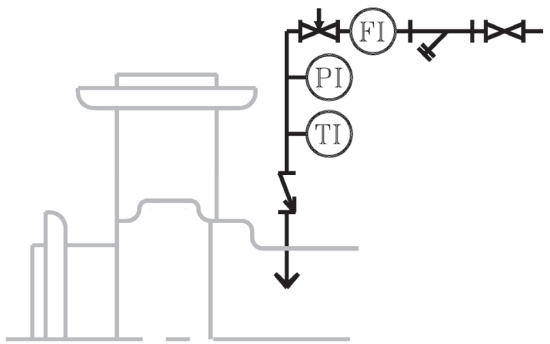

**Description:** Plan 32 is injection of a cleaner or cooler fluid to the seal chamber from an external source, mixing into the process stream.

**Objective:** Isolate fluid in the seal chamber from process. Using a close-clearance throat bushing, the injected fluid can isolate the seal from a process with poor lubricity, high temperature, abrasive, dirty, corrosive, polymerizing, or oxidizing properties. To provide cooling to the seal.

**Advantages:** Seal life can be extended and vapor margin increased.

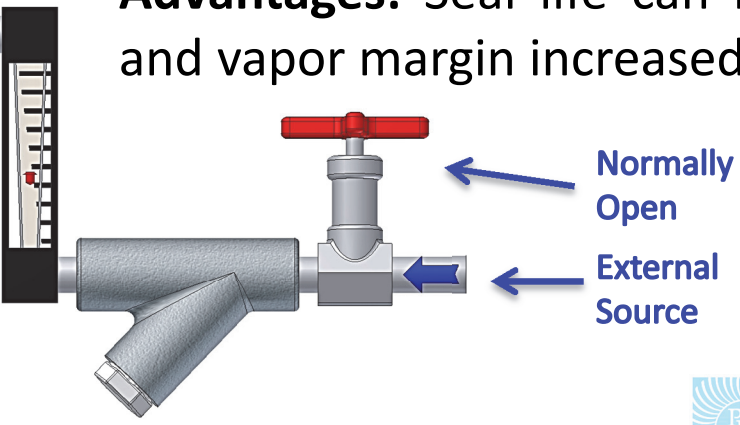
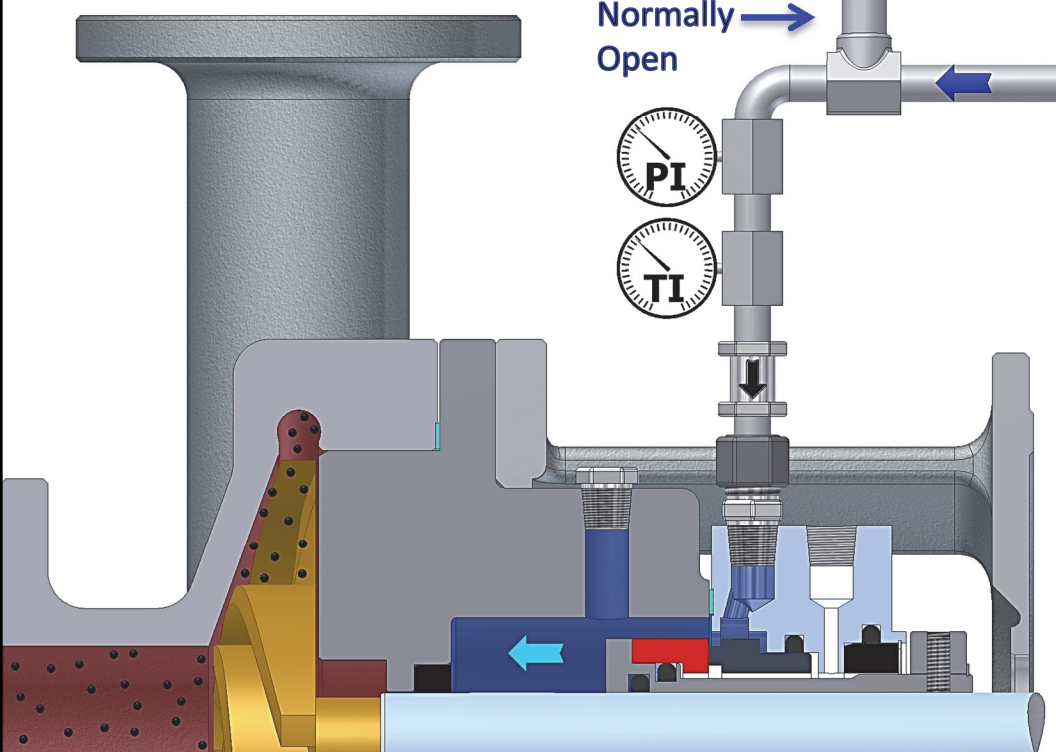

**Caution:** The cost of process dilution and/or water removal sometimes exceeds the savings created with longer seal life.



# Plan 41

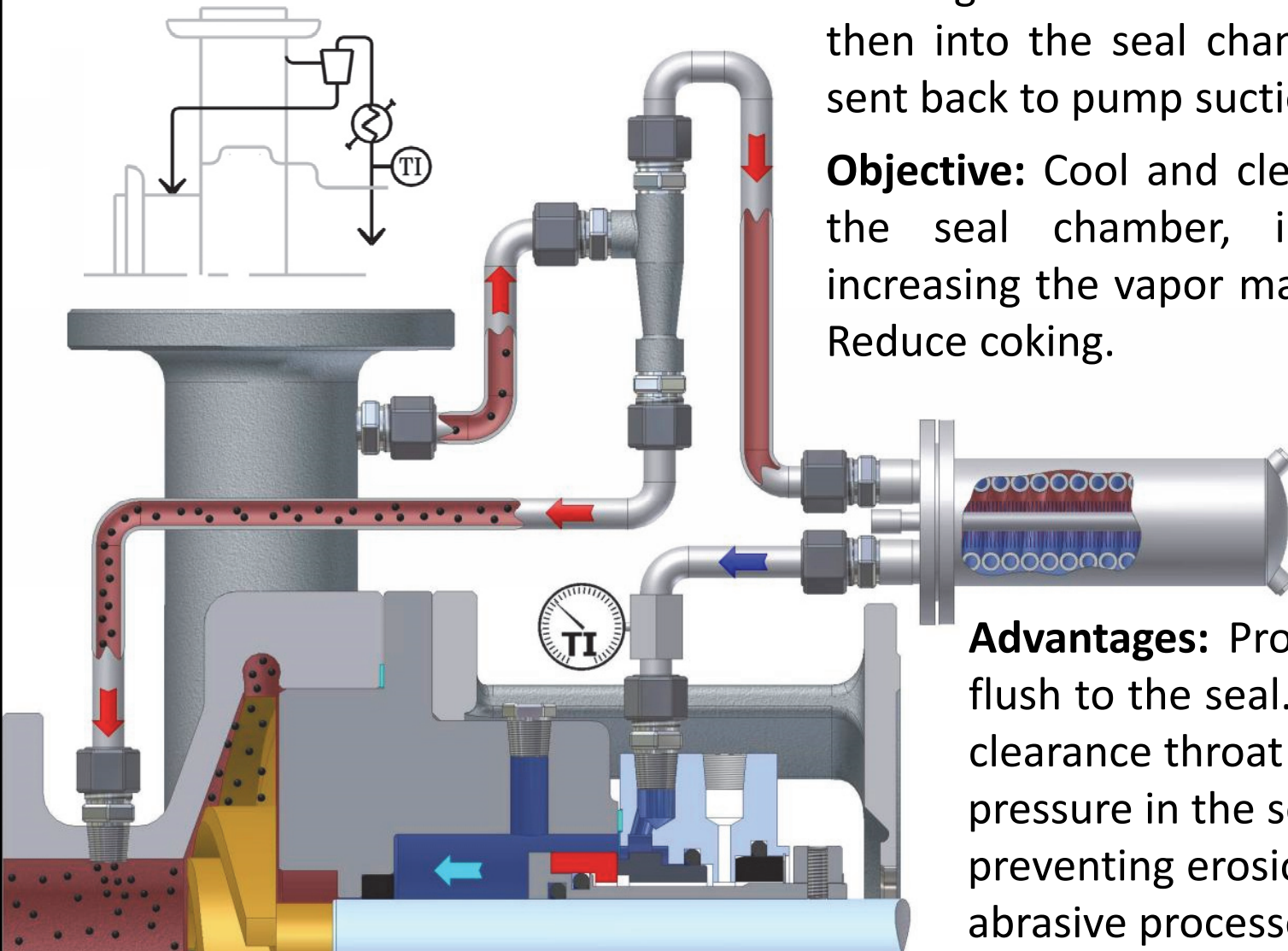

**Description:** Plan 41 is recirculation from pump discharge through a CYCLONE SEPARATOR, sending clean flush through a seal flush cooler, then into the seal chamber. Heavy particles are sent back to pump suction.

**Objective:** Cool and clean process being sent to the seal chamber, improving lubricity and increasing the vapor margin in the seal chamber. Reduce coking.



**Advantages:** Provides cooler and cleaner flush to the seal. When used with a close-clearance throat bushing, can raise the pressure in the seal chamber while preventing erosion to the seal from abrasive processes.

# Plan 52

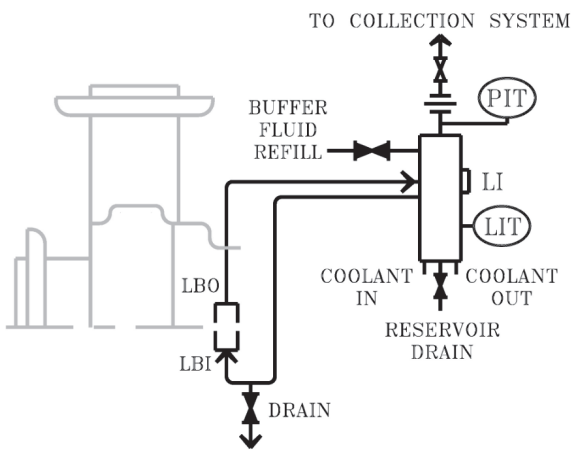

To Vent/  
Collection System,  
Normally Open

Buffer Fluid  
Refill

Normally  
Closed

Level  
Indicator

Coolant  
In

Drain,  
Normally Closed

Coolant  
Out

**Description:** Plan 52 is an external reservoir, typically NON-PRESSURIZED or maintained at a pressure less than the pressure in the seal chamber. Provides BUFFER fluid for the outer seal of an Arrangement 2 dual seal. Circulation provided by an internal pumping ring.

**Objective:** To reduce human and environmental contact in the event of a primary seal failure. Lubricate outer seal.

**Advantages:** No process contamination. Enhanced cooling available using cooling coils in the reservoir. Best for hazardous fluids, light hydrocarbons and vapors which are contained by a safety backup seal.



# Plan 53A

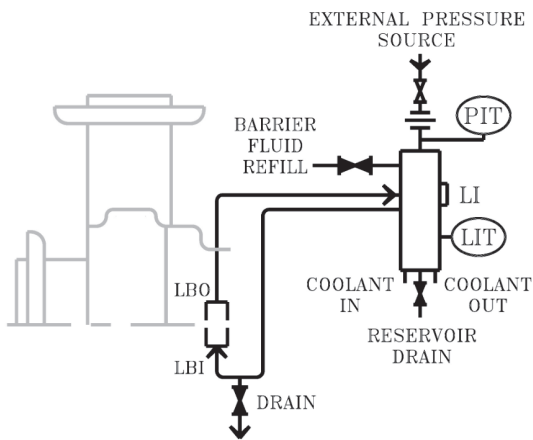

Pressure Source,  
Normally Open

Barrier Fluid  
Refill

Normally  
Closed

Level  
Indicator

Coolant  
In  
 Drain,  
Normally Closed  
 Coolant  
Out

**Description:** Plan 53A is an external reservoir, PRESSURIZED greater than the seal chamber pressure. Provides clean BARRIER fluid to an Arrangement 3 dual seal. Typically pressure is provided by nitrogen gas below 200 psig. Circulation provided by an internal pumping ring.

**Objective:** Provide favorable environment for long seal life. Ensure zero process emissions to environment.

**Advantages:** Prevents human and environmental contact with process. Enhanced cooling available using cooling coils. Best for toxic, hazardous, polymerizing, abrasive fluids and light hydrocarbons.



# Plan 53B

**Description:** Plan 53B utilizes a pre-pressurized BLADDER ACCUMULATOR isolating pressurized gas from barrier fluid and providing a PRESSURIZED system greater than the process pressure being sealed. Provides clean BARRIER fluid to an Arrangement 3 dual seal. Circulation provided by an internal pumping ring.

**Objective:** Same as Plan 53A, but handles higher pressures.

**Advantages:** Same as Plan 53A. Prevents pressurized gas entrainment. Additional cooling provided by finned tubing, forced air cooled or water cooled barrier cooler depending on heat load.

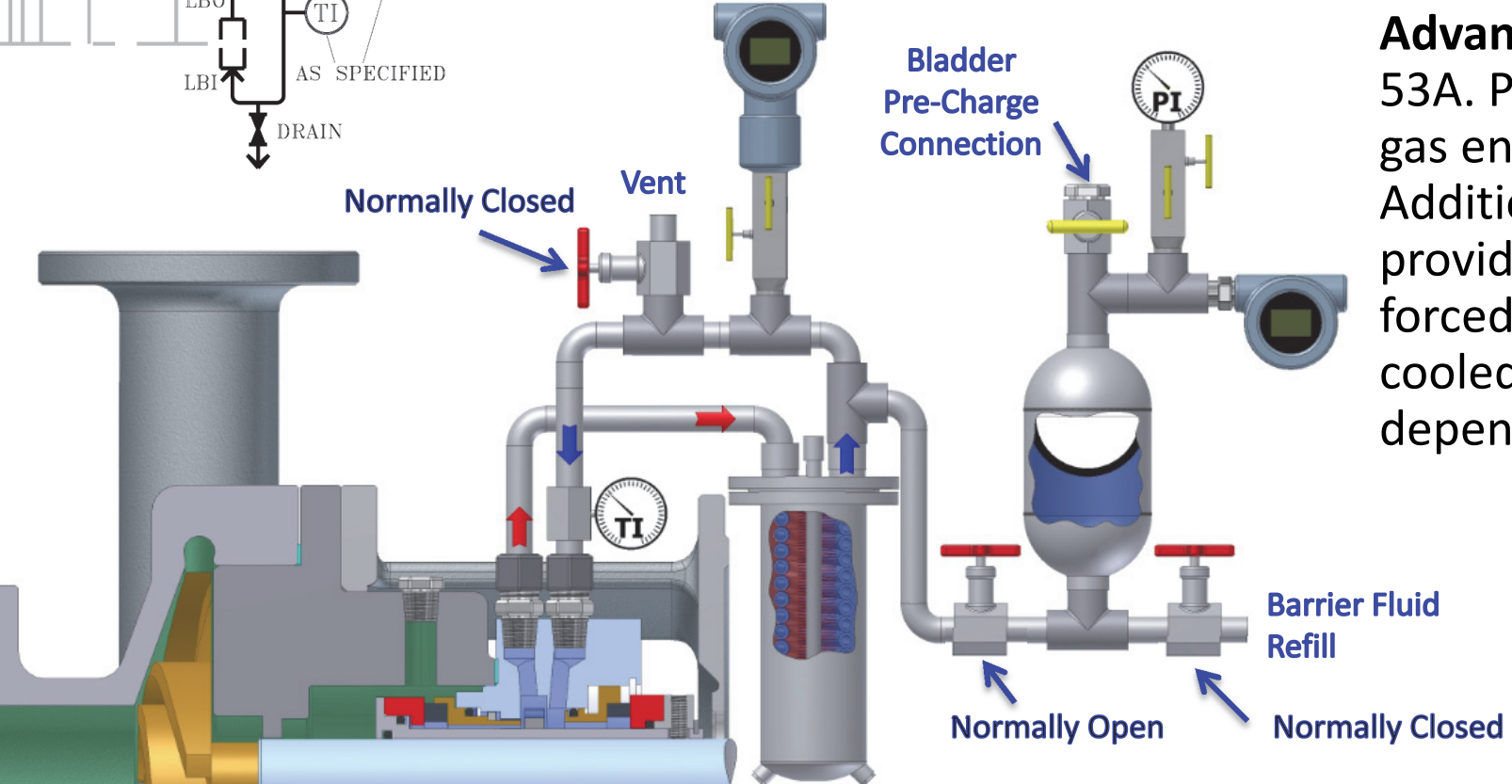
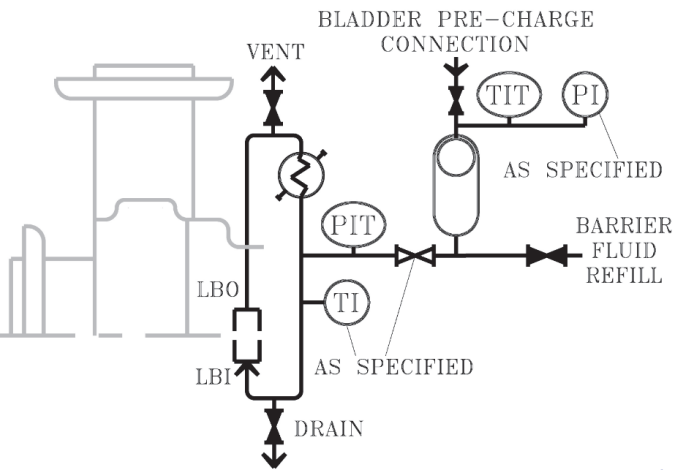

# Plan 53C

**Description:** Plan 53C utilizes a reference line from the process in the seal chamber as a pressure source to a PISTON ACCUMULATOR. Provides a PRESSURIZED system greater than the process pressure being sealed, providing clean BARRIER fluid to an Arrangement 3 dual seal. Circulation provided by an internal pumping ring.

**Objective:** Same as Plan 53A, but will handle higher pressures and maintain a constant differential pressure above process pressure on the inner seal.

**Advantages:** Same as Plan 53B. Minimizes pressure reversals and maintains process seal stability.

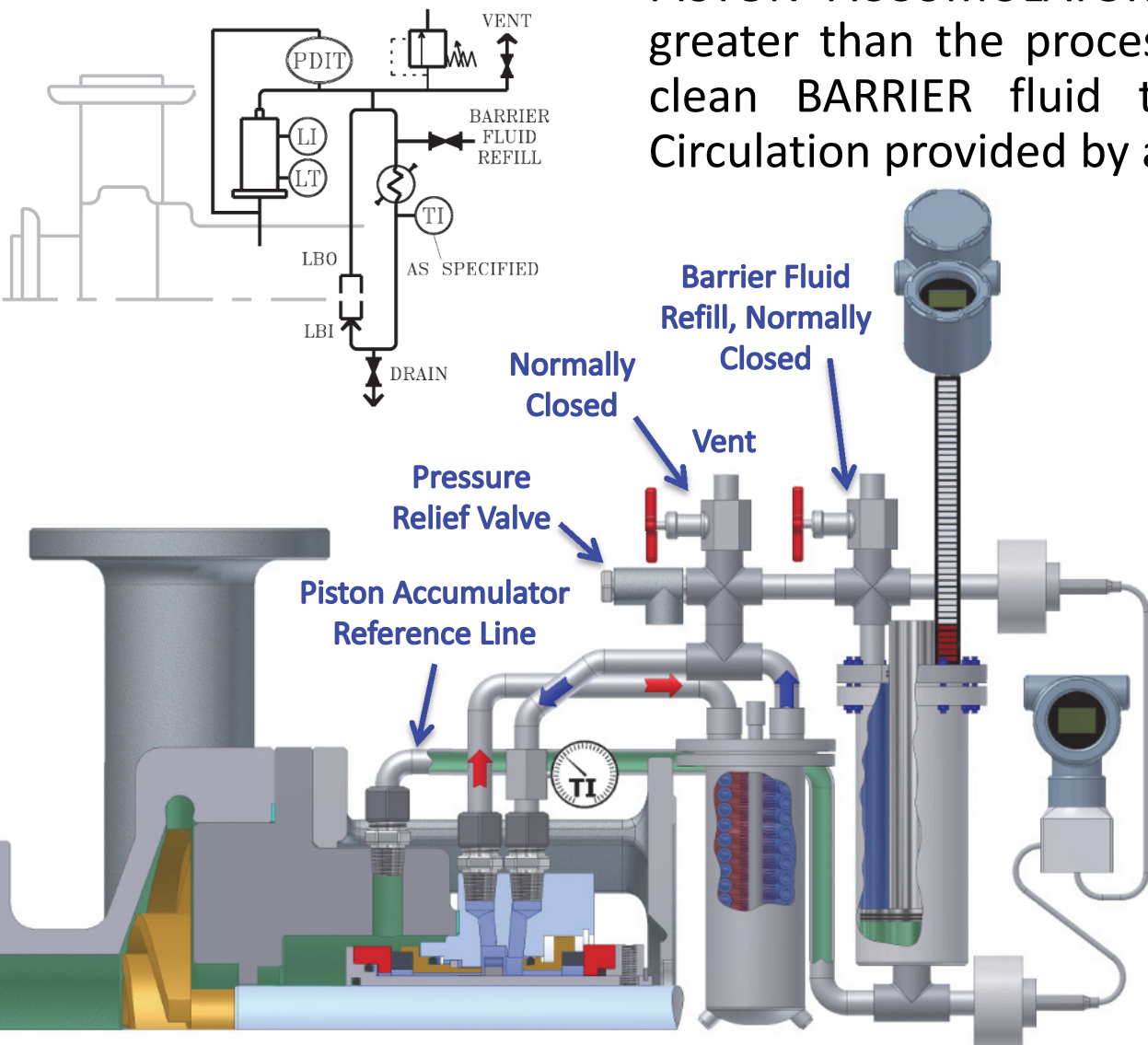

# Plan 54

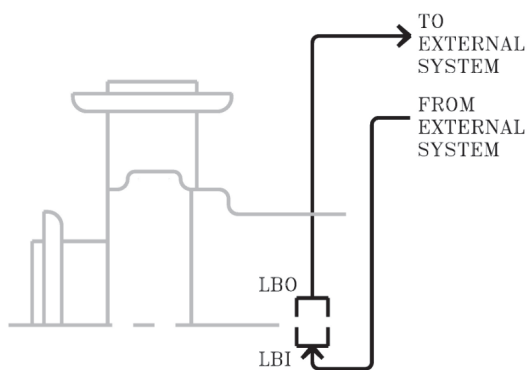

**Description:** Plan 54 is an external system supplying clean BARRIER fluid to an Arrangement 3 dual seal at greater pressure than the process pressure being sealed. Pressure and circulation are provided for by an external pump or pressure system.

**Objective:** Same as Plan 53A and will provide constant pressure and flow through circulation system.

**Advantages:** Same as Plan 53A but provides excellent circulation and cooling. Can be used on multiple seals to reduce cost. The barrier fluid enters the seal and exits in a once in and once out fashion.



# Plan 55

Plan 55 is similar to Plan 54 except the system is supplying clean BUFFER fluid at less pressure than the process pressure being sealed, to an Arrangement 2 dual seal. No process contamination and improved cooling over Plan 52.

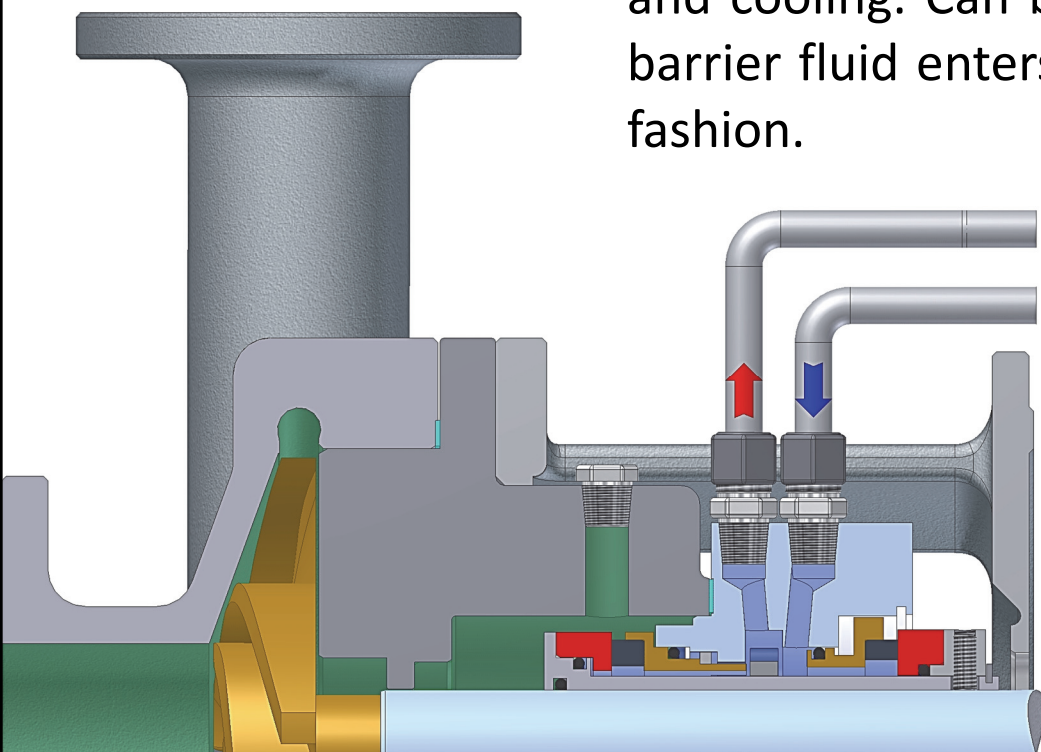

# Plan 62

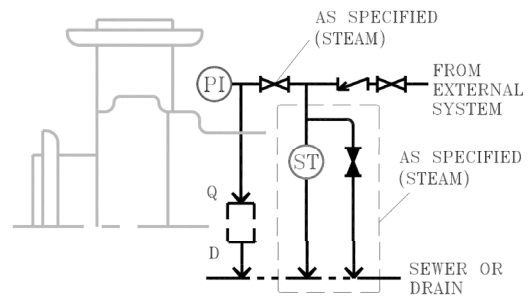

**Description:** Plan 62 is an external source supplying quench (nitrogen, water, steam, etc.) on the atmosphere side of the seal. Typically used with a throttle bushing or auxiliary sealing device for containment.

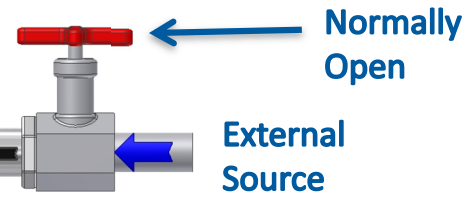
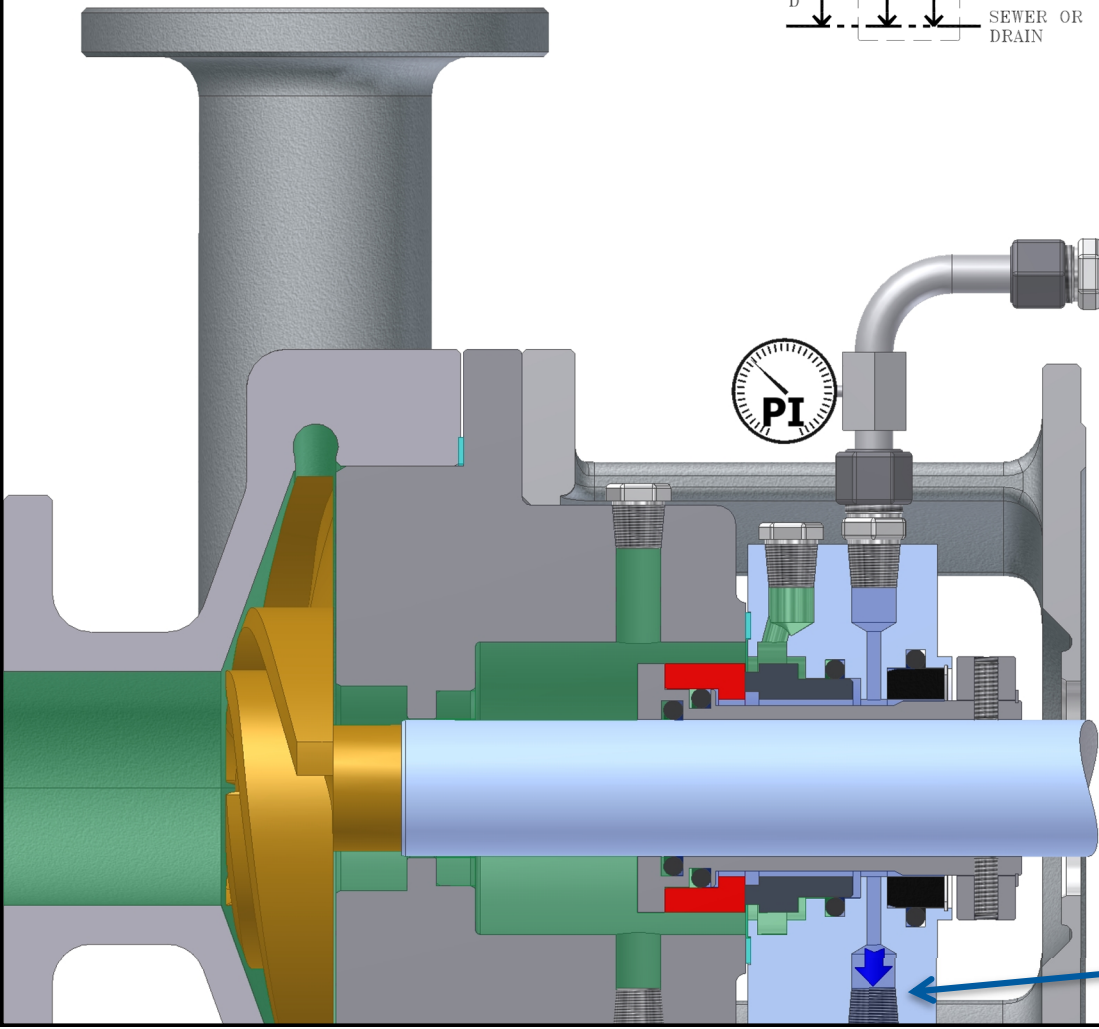

**Objective:** To reduce oxidation, coking or crystallization of process accumulating on the atmospheric side of the seal.

**Advantages:** Utilizes miniscule flow rate of water or only a “whisper” of nitrogen or steam (2-4 psi). Can also provide some heating or cooling.



Drain



# Plan 65A

**Description:** Plan 65A is a liquid leakage detection system measured by a level transmitter, arranged to set off an alarm when EXCESSIVE leakage occurs. Normally for

Arrangement 1 single seals. The orifice downstream of the level transmitter is typically 1/4" located in a vertical piping leg. Includes a bypass around the orifice to prevent pressure build up. Use with close-clearance gland throttle bushing.

**Objective:** Safely control continuous draining to liquid collection system and alarm or shut pump down when excessive.

**Advantages:** Used for remote locations and critical processes. May be used with Plan 62 quench to reduce oxidation/coking build-up.

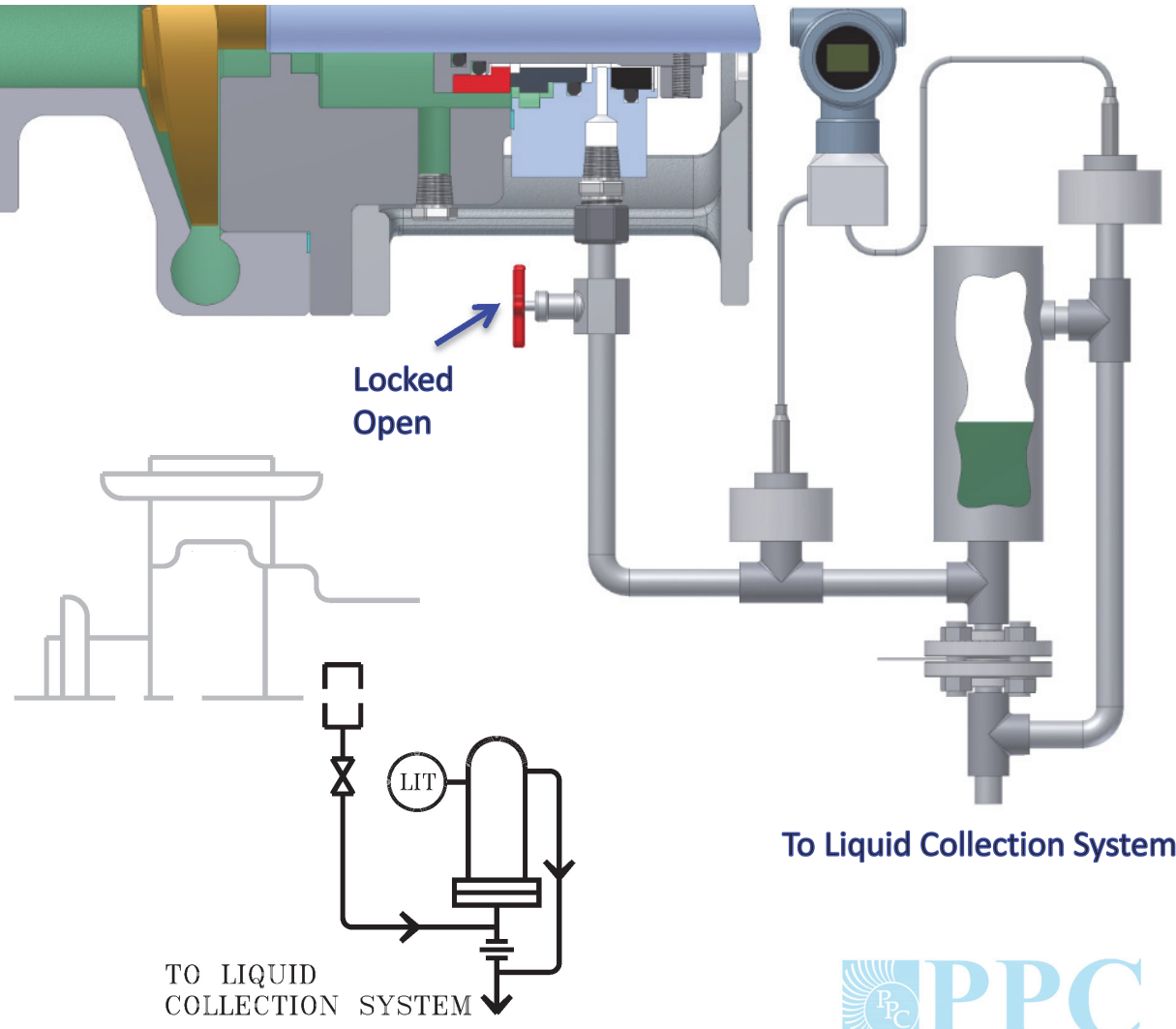

# Plan 65B

**Description:** Plan 65B is a TOTAL liquid leakage detection system measuring accumulated liquid leakage. Normally for Arrangement 1 single seals. Seal leakage will collect in a

containment vessel with a level transmitter and bypass line to prevent pressure build up. This plan will require that the operator periodically drain the collection vessel to allow for continuous operation. Use with close-clearance gland throttle bushing.

**Objective:** Safely detect seal failure and allow for shutting down the pump and containing seal leakage.

**Advantages:** Monitors ALL leakage to atmosphere. For remote locations and critical processes.

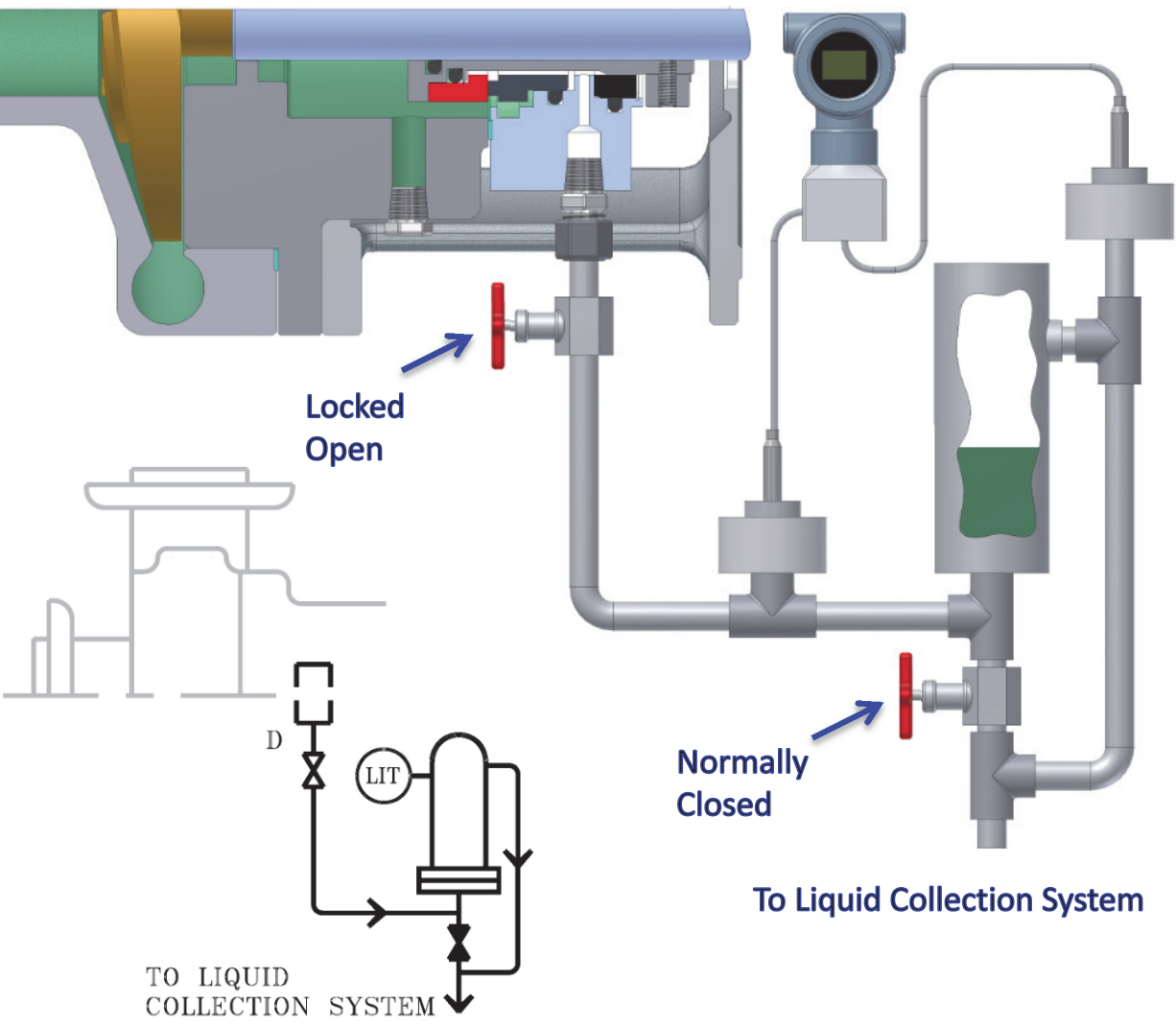

# Plan 66A

**Description:** Plan 66A is an external drain with an external pressure transmitter to detect high level leak rates. Normally for Arrangement 1 single seals. Pressure port and drain are separated by a gland bushing with an additional gland bushing on atmosphere side.

**Objective:** Detect seal failure early and minimize leakage past gland. Typically used on single seals in remote locations and critical processes.

**Advantages:** More efficient directing leakage to a drain than Plan 66B.

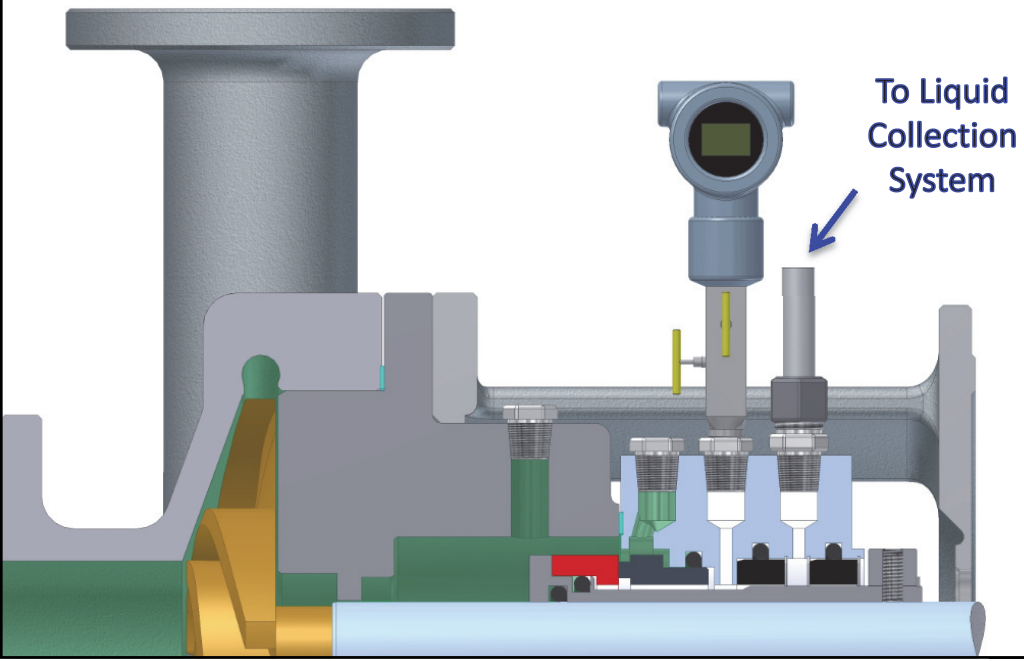
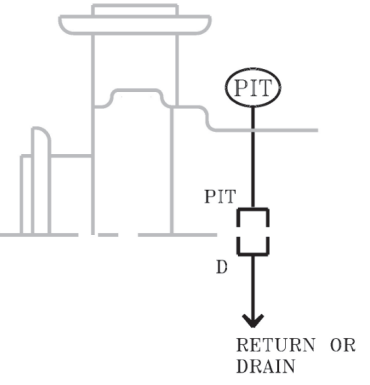

# Plan 66B

**Description:** Plan 66B is an external drain

with an orifice plug and an external pressure transmitter to detect high level leak rates on atmosphere side of seal, utilizing a single gland bushing. Normally for Arrangement 1 single seals.

**Objective:** Same as Plan 66A.

**Advantages:** Can easily adapt to most existing seal glands.

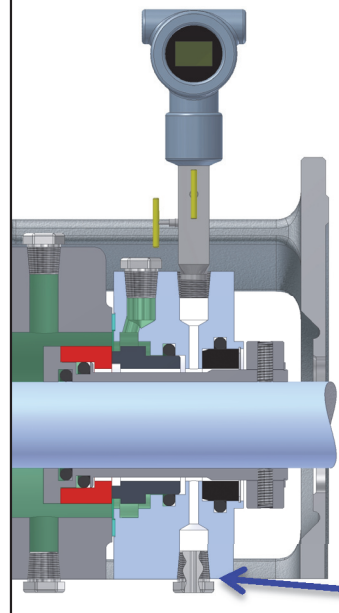

# Plan 72

**Description:** Plan 72 is an external control system supplying a “whisper” of BUFFER gas (typically Nitrogen) at less pressure than the process pressure being sealed, to an Arrangement 2 dual gas seal, with a dry running containment seal. Used alone to dilute seal leakage or in conjunction with Plan 75 or 76 to help sweep seal leakage into a closed collection system.

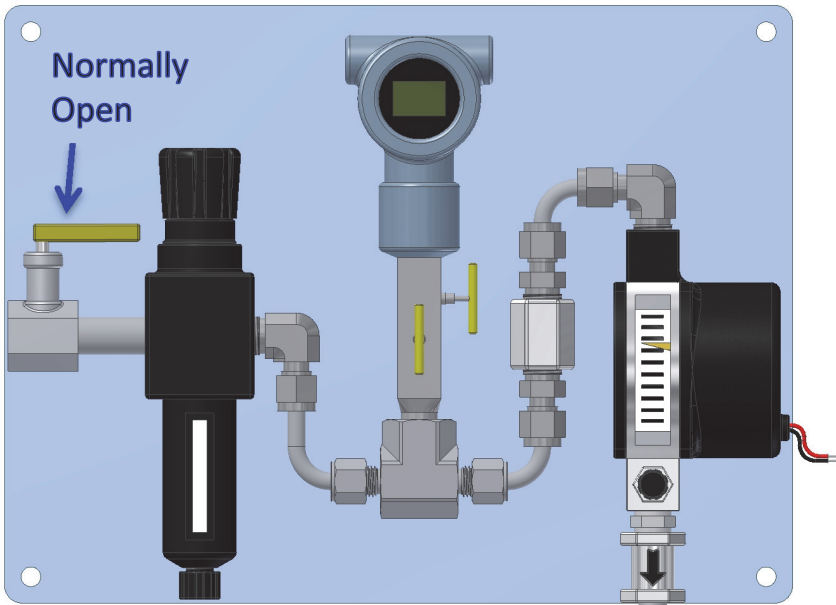
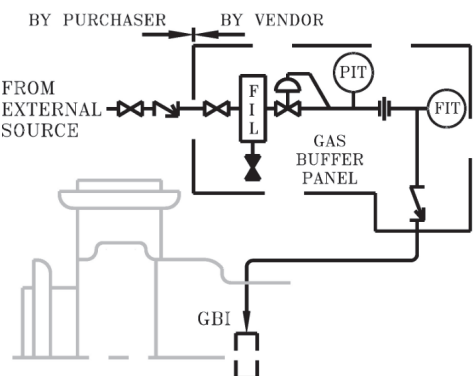

Used alone to dilute seal leakage or in conjunction with Plan 75 or 76 to help sweep seal leakage into a closed collection system.

**Objective:** To reduce human and environmental contact in the event of a primary seal failure. Remove moisture, filter the gas and regulate the pressure to the seal.

**Advantages:** Zero to very low process emissions.

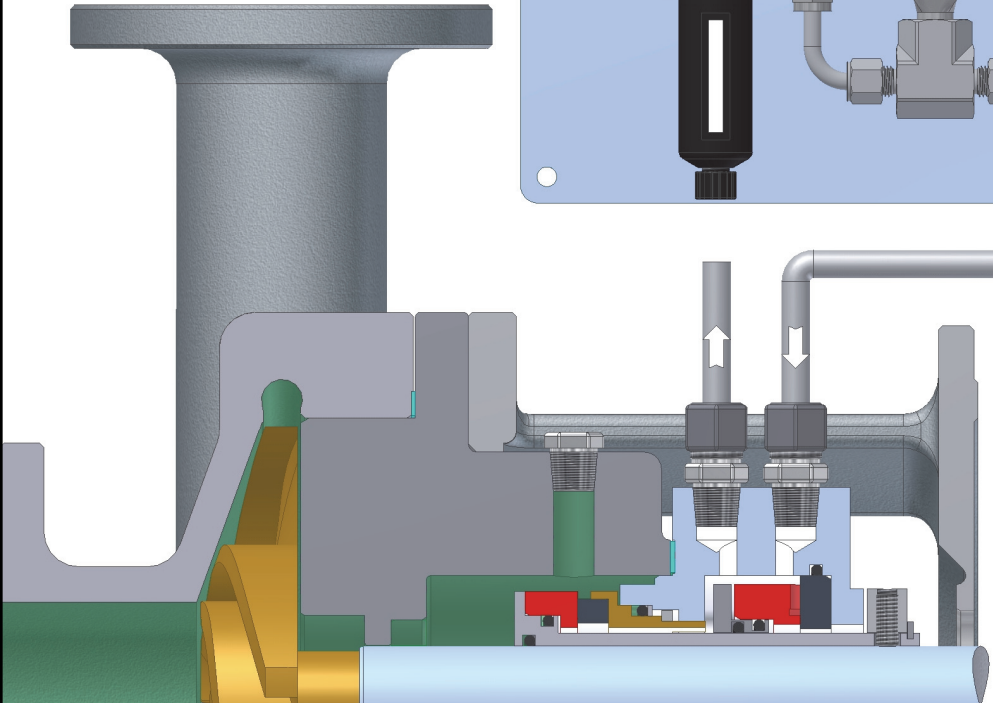

# Plan 74

**Description:** Plan 74 is an external control system supplying BARRIER gas (typically Nitrogen) at greater pressure than the process pressure being sealed, to an Arrangement 3 dual gas seal.

**Objective:** Prevent process from leaking to the atmosphere. Remove moisture, filter the gas and regulate the pressure to the seal. Best for hazardous, non-polymerizing, non-oxidizing fluids, light hydrocarbons and vapors.

**Advantages:** For processes that do not tolerate a liquid barrier. Can be used with LIFT OFF seal faces that generate no heat or wear and can have significantly increased seal life. Lower cost and maintenance than dual liquid systems.

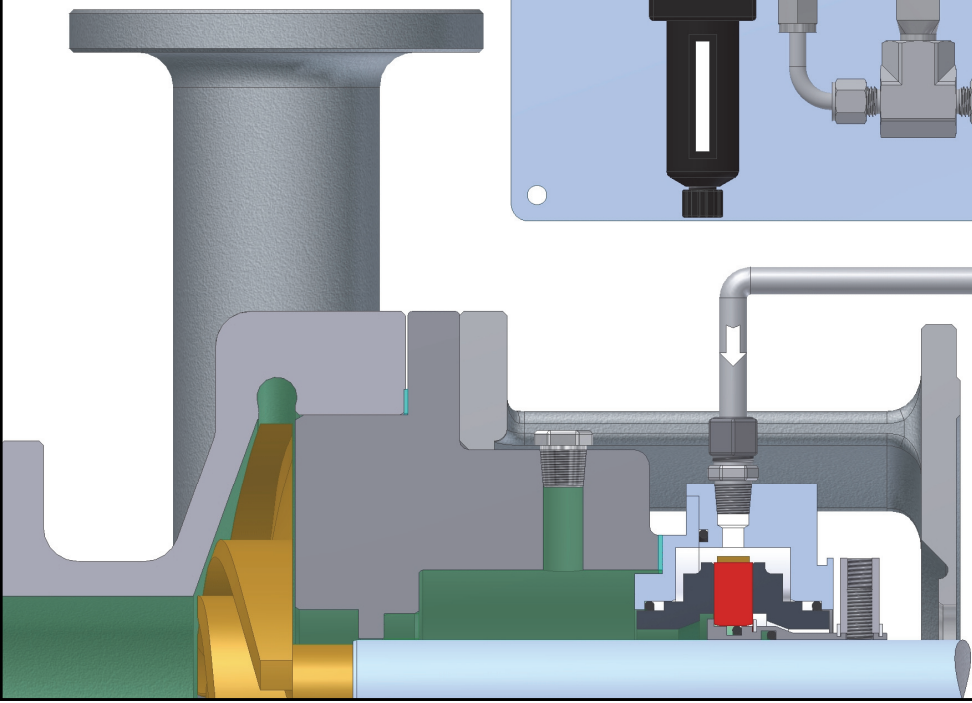
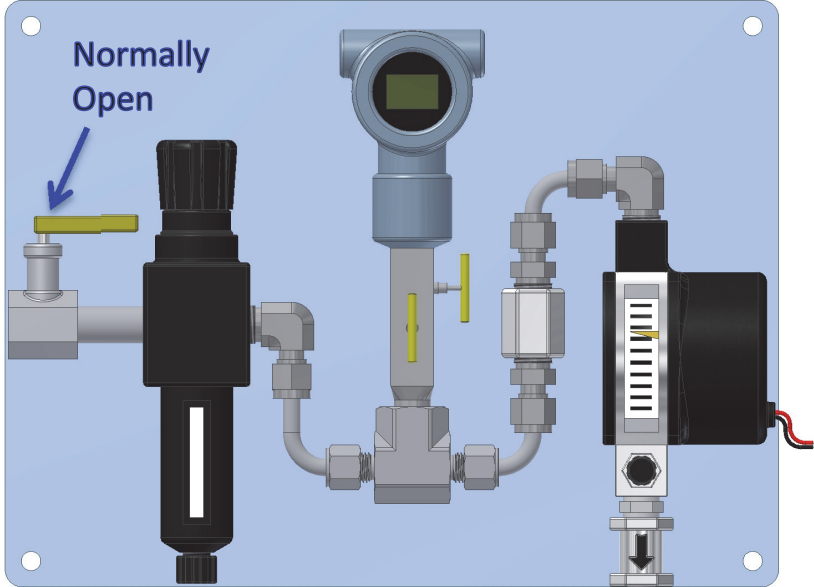
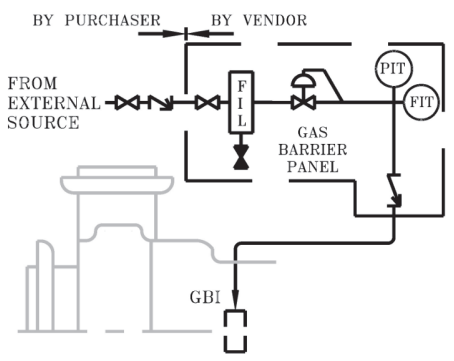

# Plan 75

**Description:** Plan 75 is a containment seal chamber which allows draining of condensing leakage on Arrangement 2 dual seals. The collection system is located below the seal chamber and uses an orifice and a pressure transmitter to detect high vapor leak rates. Typically used with contacting secondary containment seals.

**Objective:** Contain and vent leakage to collection system while monitoring leak rate. Orifice sized to allow maximum leakage and pressure alarm to shut down the pump if the leak rate is excessive.

**Advantages:** Best for processes that condense at ambient temperatures. Can be used with Plan 72 to sweep the leakage into the containment system. Lower cost and maintenance than dual liquid systems.

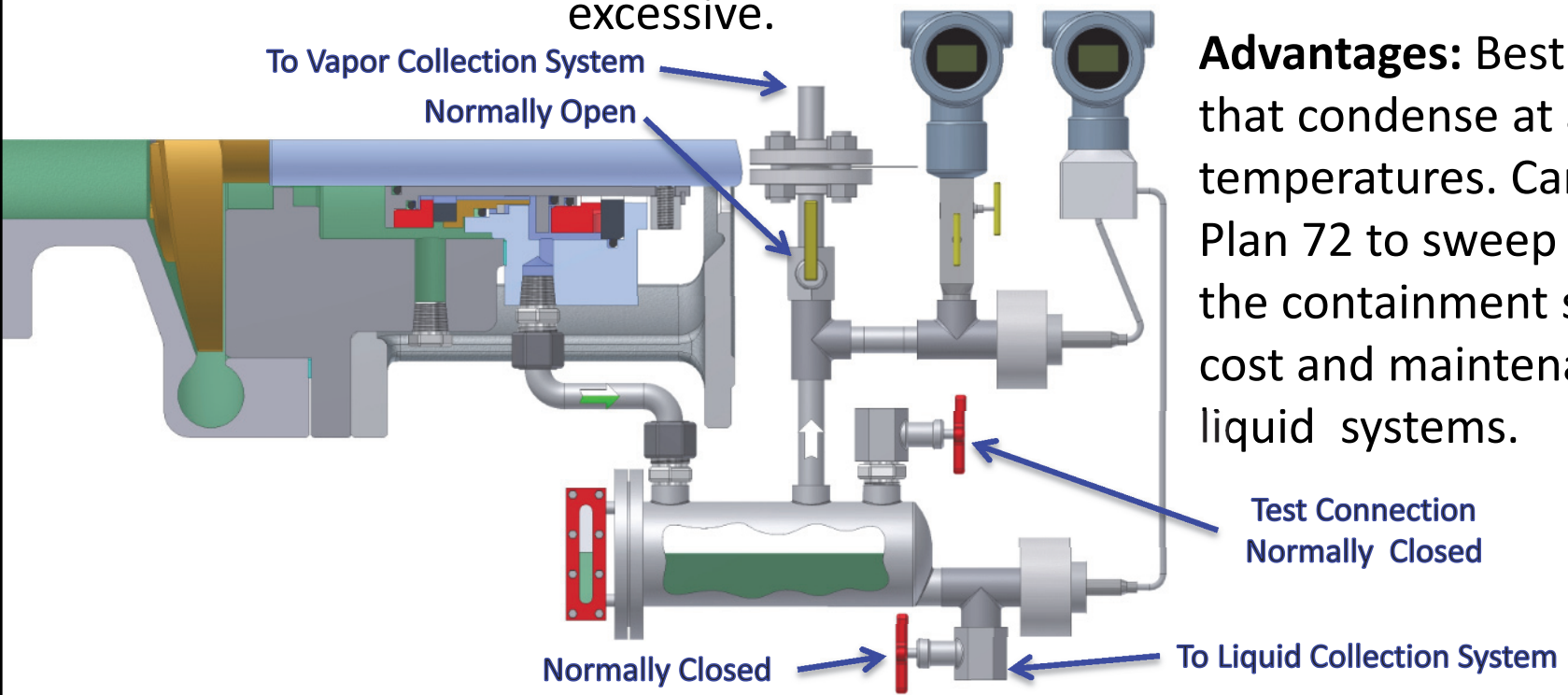
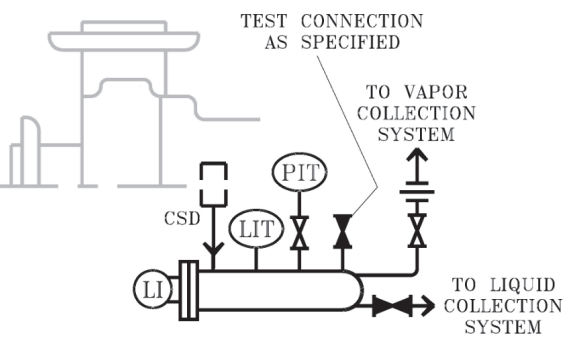

# Plan 76

TO COLLECTION SYSTEM

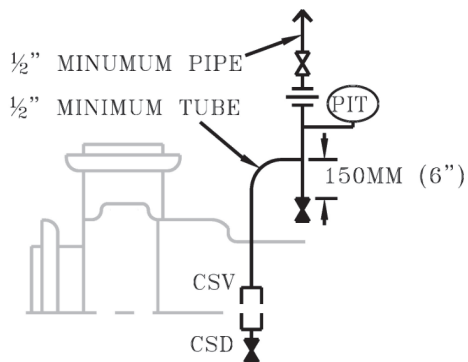

**Description:** Plan 76 is a containment seal chamber which allows venting of non-condensing leakage from an Arrangement 2 dual seal, to a flare or vapor recovery system.

**Objective:** Vent leakage to recovery while monitoring leak rate by sizing the orifice to allow maximum leakage. Pressure transmitter will shut down the pump if the leak rate is excessive.

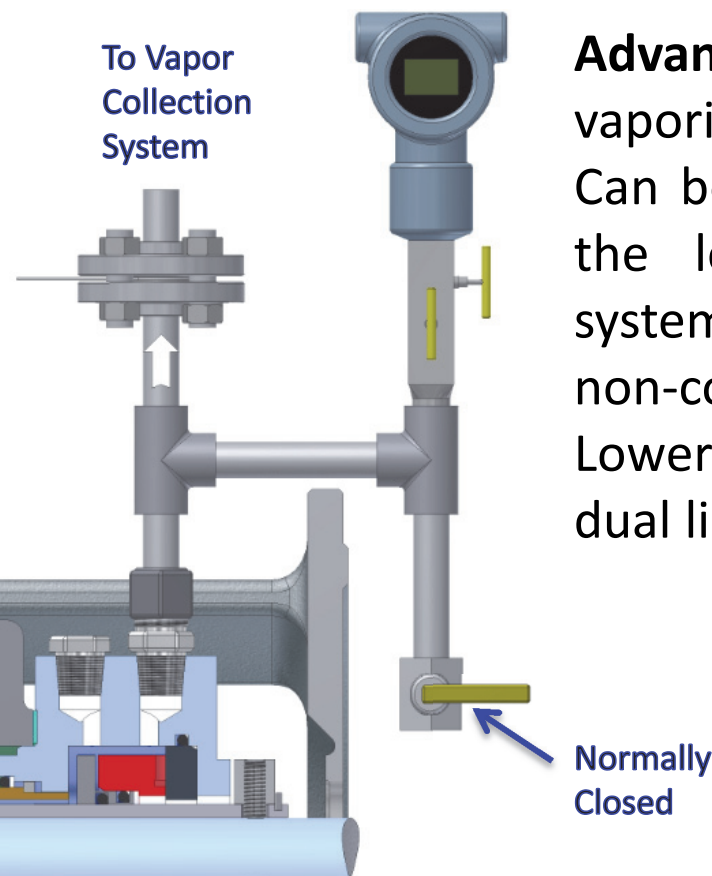

**Advantages:** Best for processes that vaporize at ambient temperatures. Can be used with Plan 72 to sweep the leakage into the monitoring system. Is used with contacting or non-contacting containment seals. Lower cost and maintenance than dual liquid systems.

# Legend



BLADDER  
ACCUMULATOR



LEVEL/DP  
TRANSMITTER,  
LOCAL INDICATOR



TEMPERATURE  
TRANSMITTER,  
LOCAL INDICATOR



PRESSURE  
TRANSMITTER,  
LOCAL INDICATOR



FLOW  
TRANSMITTER,  
LOCAL INDICATOR



MAGNETIC  
LEVEL INDICATOR  
WITH TRANSMITTER



PRESSURE  
REGULATOR  
WITH FILTER



PISTON  
ACCUMULATOR



CYCLONE  
SEPERATOR

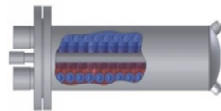

COOLER



CHECK  
VALVE



TEMPERATURE  
INDICATOR

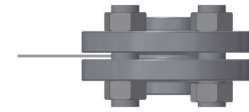

FLANGED  
ORIFICE



ORIFICE PLUG



LIQUID FLOW  
INDICATOR



SEAL  
RESERVOIR



COMPRESSION  
FITTING



PRESSURE  
RELIEF VALVE



PRESSURE  
INDICATOR

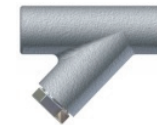

Y-STRAINER

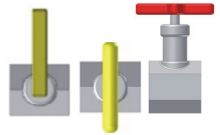

VALVES



GAS FLOW  
INDICATOR

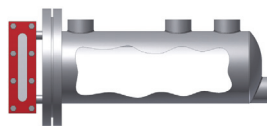

LEAKAGE RESERVOIR



STEAM  
TRAP

API 682 4<sup>th</sup> Edition



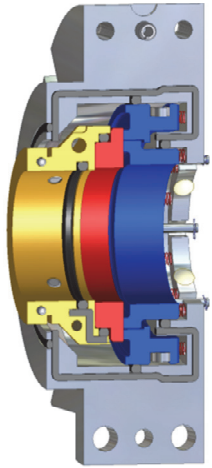

Split Seals

We are your Solution to Mechanical Seal Problems  
Through Innovative Engineering & Expert Technical Service.

Contact Us and We'll Show You.

[www.ppcmechanicalseals.com](http://www.ppcmechanicalseals.com)  
[sales@ppcmechanicalseals.com](mailto:sales@ppcmechanicalseals.com)  
1-800-731-7325 • 1-225-356-4333  
Baton Rouge, LA  
USA

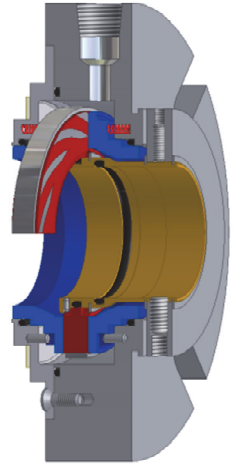

Non-contacting  
Seals

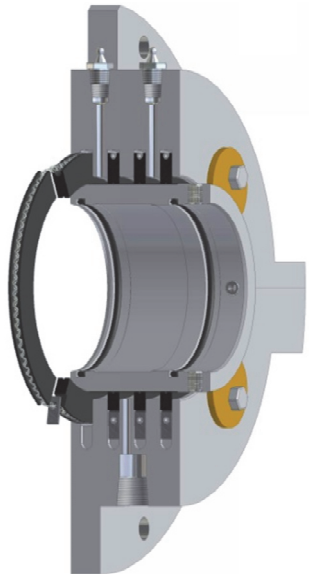

Split Bushing  
Seals

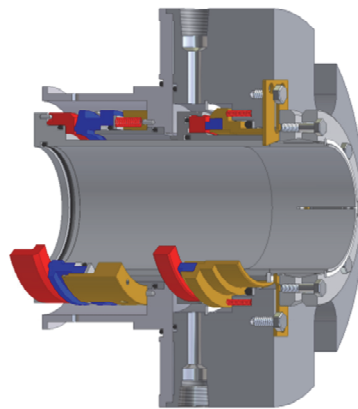

High Pressure  
Seals

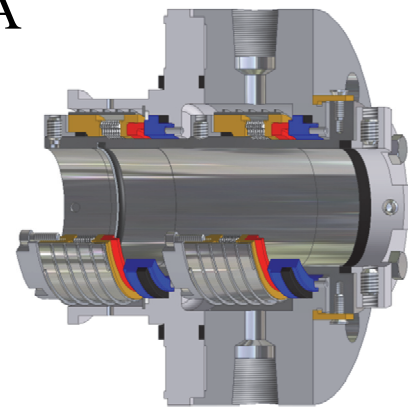

High Temperature  
Metal Bellows Seals

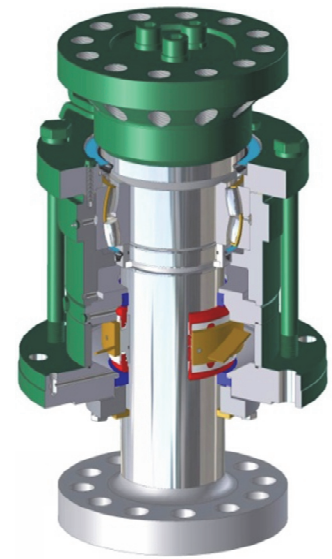

Mixer Seals